

# INSTALLATION AND OPERATING INSTRUCTIONS

Models 260-401  
Type WH

## ECONOPAK WATER HEATERS

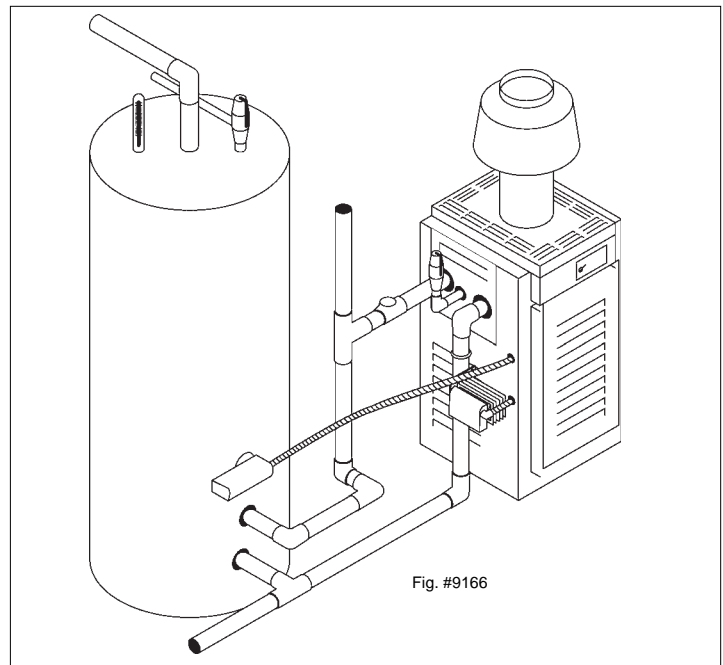

### FOR YOUR SAFETY

Do not store or use gasoline or other flammable vapors and liquids or other combustible materials in the vicinity of this or any other appliance. To do so may result in an explosion or fire.

**WARNING:** Improper installation, adjustment, alteration, service or maintenance can cause property damage, personal injury or loss of life. Refer to this manual. Installation and service must be performed by a qualified installer, service agency or the gas supplier.

### FOR YOUR SAFETY

#### WHAT TO DO IF YOU SMELL GAS

- \*Do not try to light any appliance.
- \*Do not touch any electrical switch; do not use any phone in your building.
- \*Immediately call your gas supplier from a neighbor's phone. Follow the gas supplier's instructions.
- \*If you cannot reach your gas supplier, call the fire department.

This manual should be maintained in legible condition and kept adjacent to the heater or kept in a safe place for future reference.



# Raypak®

A Rheem® Company

## TABLE OF CONTENTS

### CONTENTS

<b>3</b>	<b>1. RECEIVING EQUIPMENT</b>
<b>3</b>	<b>2. GENERAL SPECIFICATIONS AND DIMENSIONS</b>
4	General Safety Precautions
<b>6</b>	<b>3. INSTALLATION PROCEDURES</b>
6	- Code Requirements
6	- Clearance Requirements for all Models
6	- Combustion/Ventilation Air
7	- Venting Connections
8	- Common Vents
10	- Gas Supply Connections
11	- Water Connections & System Piping
13	- Electrical Wiring
14	- Wiring Diagrams
<b>19</b>	<b>4. SERVICING PROCEDURES</b>
19	- Sequence of Operation
19	- Start Up Procedures
24	- Inspection Procedures
25	- Repair Section
<b>26</b>	<b>5. TROUBLE SHOOTING GUIDE</b>
<b>30</b>	- Adjustments/Replacements of Components
<b>33</b>	<b>6. REPLACEMENT PARTS LIST</b>
<b>35</b>	<b>WARRANTY</b>

These instructions are provided to assure the proper installation and operation of Raypak water heaters. Should questions arise regarding the specifications, installation, operation or servicing of these water heaters, we suggest that the local Sales representative or the factory be consulted.

## 1. RECEIVING EQUIPMENT

On receipt of your equipment it is suggested that you visually check for external damage to the carton. If the carton is damaged, it is suggested that a note be made on the Bill of Lading when signing for equipment. Remove the heater from the carton and if it is damaged report the damage to the carrier immediately. Be sure that you receive the number of packages indicated on the Bill of Lading. **Claims for shortages and damages must be filed with carrier by consignee.**

Purchased parts are subject to replacement only under the manufacturer's warranty. Debits for defective replacement parts will not be accepted and defective parts will be replaced in kind only per our standard warranties.

When ordering parts, you must specify Model and Serial Number of the heater. When ordering under warranty conditions, you must also specify date of installation.

**Raypak recommends that this manual be reviewed thoroughly before installing your Raypak heater. If there are any questions which this manual does not answer, please contact your local Raypak representative.**

## 2. GENERAL SPECIFICATIONS

The Raypak water heaters are design certified by the and tested under the requirements of the American National Standard, **ANSI Z21.10.3**. Each heater has been constructed and pressure tested in accordance with the requirements of Section IV of the American Society of Mechanical Engineers Code, and factory fire tested.

These heaters are designed for indoor and outdoor installations, and can be installed on combustible flooring when the appropriate listed floor shield base is used. Models are available with standing pilot or with intermittent ignition device (IID), and are equipped with the following components as standard: water circulation pump, pressure relief valve, manual reset high limit switch, fast response temperature controller, vent thermal and flame roll-out switches (except for models 330 and 400), a solid state Economaster pump control relay, 40VA transformer, and redundant combination gas valve for use with either Natural or Propane gases. A tankstat is supplied loose for installation in the field.

### SPECIFICATIONS AND DIMENSIONS

Model WH	Input MBH	Recovery GPH‡ Indoor	Tank Gal*	Piping Connections		Dimensions (Inches)					
				Water NPT	Gas NPT	A	J	K	L	M	N
260/261	264	262	80	1-1/2	3/4	21	11-1/8	8	11-1/4	8-1/2	3-7/8
330/331	333	331	80	1-1/2	3/4	23-3/4	10-3/4	9	14	8-1/2	3-7/8
400/401	399	396	80	1-1/2	1	27-1/4	12-1/2	10	17-3/8	8-1/2	3-7/8

\*May be used with other tank size capacity.

‡ Recovery based on manufacturer's rating

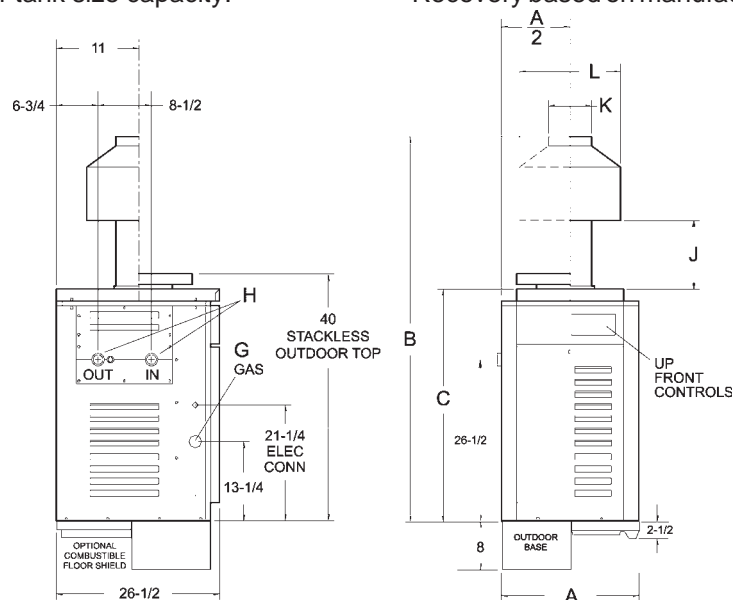

## ⚠ General Safety Precautions

Be sure to read and understand the entire Instruction Manual before attempting to install or operate this water heater. Pay particular attention to the following general Safety Precautions. Failure to follow these warnings could result in a fire or explosion, causing property damage, bodily injury or death. Should you have any problems understanding the instructions in this manual, STOP, and get help from a qualified installer or service technician or the gas supplier.

### ⚠ WARNING

Gasoline, as well as other flammable materials and liquids (adhesives, solvents, etc.), and the vapors they produce, are extremely dangerous. DO NOT handle, use or store gasoline or other flammable or combustible materials anywhere near or in the vicinity of a water heater. Be sure to read and follow the warning label pictured below and other labels on the water heater, as well as the warnings printed in this manual. Failure to do so can result in property damage, bodily injury, or death.

### ⚠ DANGER

Failure to install the draft hood and properly vent the water heater to the outdoors as outlined in the Venting Section of this manual can result in unsafe operation of the water heater. To avoid the risk of fire, explosion, or asphyxiation from carbon monoxide, never operate this water heater unless it is properly vented and has an adequate air supply for proper operation. Be sure to inspect the vent system for proper installation at initial start-up; and at least annually thereafter. Refer to Maintenance section of this manual for more information regarding vent system inspections.

⚠ DANGER



**⚠ Vapors from flammable liquids will explode and catch fire causing death or severe burns.**

Do not use or store flammable products such as gasoline solvents or adhesives in the same room or area near the water heater.

Keeflammable products:

1. far away from heater,
2. in approved containers,
3. tightly closed and
4. out of childrens reach.

Water heater has a main burner and pilot flame. The pilot flame:

1. is on all the timeand
2. will ignite flammable vapors.

Vapors:

1. cannot be seen,
2. are heavier than air,
3. go a long way on the floor,
4. can be carried from other room to the pilot flame by their currents.

**Installation:**  
Do not install water heater where flammable products will be stored or used unless the main burner and pilot flames

are at least 18" above the floor. This will reduce, but not eliminate, the risk of vapors being ignited by the main burner or pilot flame.

Read and follow water heater warnings and instructions. If owners manual is missing, contact the retailer or manufacturer.

### ⚠ DANGER

**LIQUEFIED PETROLEUM MODELS** – Propane, or LP gas, must be used with great caution.

- It is heavier than air and will collect first in lower areas making it hard to detect at nose level.
  - Make sure to look and smell for LP leaks before attempting to light appliance. Use a soapy solution to check all gas fittings and connections. Bubbling at a connection indicates a leak that must be corrected. When smelling to detect an LP leak, be sure to sniff near the floor too.
  - Gas detectors are recommended in LP applications and their installation should be in accordance with the manufacturer's recommendations and/or local laws, rules, regulations or customs.
  - It is recommended that more than one method be used to detect leaks in LP applications.
- IF LP GAS IS PRESENT OR SUSPECTED:**
- **DO NOT** attempt to find the cause yourself;
  - **DO NOT** try to light any appliance;
  - **DO NOT** touch any electrical switch;
  - **DO NOT** use any phone in your building.
  - Leave the building immediately and make sure that every-one else leaves also.
  - Leave the doors open for ventilation and contact the gas supplier, a qualified service agency or the fire department.
  - Keep the area clear until the service call has been made, the leak is corrected, and a qualified agency has determined the area to be safe.

### ⚠ WARNING

Both LP and natural gas have an odorant added to help detection. Some people may not physically be able to smell or recognize this odorant. If unsure or unfamiliar about the smell associated with LP or natural gas, ask the gas supplier. Other conditions, such as "Odorant Fade", which causes the odorant to "fade", or diminish in intensity can also hide or camouflage a gas leak.

### ⚠ DANGER

Water heaters utilizing Liquefied Petroleum gas (LP) are different from natural gas models. A natural gas heater will not function safely on LP gas and vice versa. Conversion from Natural gas to LP gas (or vice versa) must be done by a qualified service technician. To avoid possible equipment damage, personal injury or fire: DO NOT connect this water heater to a fuel type not in accordance with unit data plate. Propane for propane units. Natural gas for natural gas units. These units are not certified for any other type fuel.

### ⚠ WARNING

LP appliances should not be installed below-grade (for example, in a basement) if such installation is prohibited by federal, state and/or local laws, rules, regulations or customs.

## General Safety Precautions

To meet commercial hot water requirements, the tankstat is adjustable up to 190°F. However, water temperatures over 125°F. can cause severe burns instantly or death from scalds. This is the preferred starting point for setting the control for supplying general purpose hot water.

Safety and energy conservation are factors to be considered when setting the water temperature on the tankstat. The most energy efficient operation will result when the temperature setting is the lowest that satisfies the needs consistent with the application.

The following chart details the relationship of water temperature and time with regard to scald injury and may be used as a guide in determining the safest water temperature for your applications.

Temperature	Time to Produce Serious Burn
120°F.	More than 5 minutes
125°F.	1-1/2 to 2 minutes
130°F.	About 30 seconds
135°F.	About 10 Seconds
140°F.	Less than 5 seconds
145°F.	Less than 3 seconds
150°F.	About 1-1/2 seconds
155°F.	About 1 second

Table courtesy of Shiners Burn Institute

### TIME/TEMPERATURE RELATIONSHIPS IN SCALDS

The temperature of the water in the storage tank boiler can be regulated by setting the temperature dial on front of the tankstat. To comply with safety regulations, the tankstat was set at its lowest setting before shipment from the factory. The illustration below illustrates the tankstat and how to adjust the water temperature.

To adjust the water temperature, insert a small straight screwdriver into slotted screw in hole in front of tankstat and turn wheel to desired setting. Thermostat is adjustable up to 190°F.

**CAUTION!! - Hotter water increases the risk of SCALDING!**



**DANGER**

**Water temperature over 125°F can cause severe burns instantly or death from scalds.**

**Children, disabled and elderly are at highest risk of being scalded.**

**See instruction manual before setting temperature at tankstat.**

**Feel water before bathing or showering.**

**Temperature limiting valves are available, see manual.**

### ⚠ DANGER

There is a Hot Water SCALD Potential if the tankstat is set too high.

**NOTE:** When this water is supplying general purpose hot water requirements for use by individuals, a thermostatically controlled mixing valve for reducing point of use water temperature is recommended to reduce the risk of scald injury. Contact a licensed plumber or the local plumbing authority for further information.

Maximum water temperatures occur just after burner has shut off. To find hot water temperature being delivered, turn on a hot water faucet and place a thermometer in the hot water stream and read the thermometer.

### 3. INSTALLATION PROCEDURES

#### CODE REQUIREMENTS

Installation must be in accordance with **local codes**, or, in the absence of local codes, with the latest editions of the **National Fuel Gas Code, ANSI Z223.1/NFPA 54**, and the **National Electrical Code, ANSI/NFPA 70**. In Canada installations must conform with the current **CAN/CSA B149.1** and the **Canadian Electrical Code Part 1 CSA C22.2 No.1**. Where required by the authority having jurisdiction, the installation must conform to American Society of Mechanical Engineers Safety Code for Controls and Safety Devices for Automatically Fired Heaters, **CSD-1**.

#### MOUNTING BASE

The heater should be mounted on a level, noncombustible surface. Heater must not be installed on carpeting. The heater can be installed on a combustible surface only when the appropriate listed floor shield base is provided. An optional listed floor shield base is available for factory installation with the heater on all indoor models.

**NOTE:** *The heater should be located in an area where water leakage will not result in damage to the area adjacent to the appliance or to the structure. When such locations cannot be avoided, it is recommended that a suitable drain pan, adequately drained, be installed under the appliance. The pan must not restrict air flow.*

In addition, the heater shall be installed such that the gas ignition system components are protected from water (dripping, spraying, rain, etc.) during appliance operation and service (circulator replacement, control replacement, etc.).

#### CLEARANCE REQUIREMENTS FOR ALL MODELS

##### 1. Minimum clearances from combustible surfaces.

Floor	Front	Back	Right	Left	Top (Indoor)	Top (Outdoor)	Flue Vent
(1) Comb.	(2) Alcove	12"	12"	12"	39"	Unobstructed	6"

- (1) Except for carpeted flooring, heaters are certified for installation on combustible floors, when equipped with listed floor shield base.
- (2) A front clearance of at least 24" is recommended for adequate service of burner-tray and controls.

#### COMBUSTION/VENTILATION AIR (Indoor models only)

**WARNING:** *Air supply to the heater room must not be affected by mechanical exhaust vents located in other parts of the house, such as kitchen or bathroom fans, or attic blowers. Mechanical exhaust vents may create a negative pressure condition in the heater room that can become a hazard of asphyxiation, explosion or fire.*

**CAUTION:** *Combustion air must not be contaminated by corrosive chemical fumes which can damage the heater. Measures must be taken to prevent the entry of corrosive chemical fumes to the combustion and ventilation air supply. Such chemicals include, but are not limited to, chlorinated and/or fluorinated hydrocarbons such as found in refrigerants, aerosol propellants, dry-cleaning fluids, degreasers, and paint removers. Other harmful elements may come from bleaches, air fresheners, or mastics. Vapors from these types of products can form corrosive acid compounds when burned in a gas flame. The resulting acid condensate can damage or substantially reduce the life of the heater. It may be necessary to provide outside air directly to the heater in order to avoid this problem.*



- 1) The heater must be provided with adequate supply of air for proper combustion and ventilation in accordance with the latest edition of the **National Fuel Gas Code, ANSI Z223.1**, or applicable provisions of the local building codes.
- 2) When the heater is installed in a confined space where all air is supplied from inside the building, the heater room must be provided with **two** openings, each one having a minimum net free area, in square inches as follows:

<u>Model</u>	<u>Sq. In. Of Free Area</u>
260	264
330	333
400	399

One opening shall be within 12 inches of the top, and the other opening within 12 inches of the floor. If additional gas appliances are installed in the same space, the total input of all gas appliances installed in the same space, must be considered in the calculation. Refer to Sec. 5.3.5 of the latest edition of the National Fuel Gas Code for additional requirements.

**NOTE:** *If louvers, grills or screens are used on the openings, obtain the net free area from their supplier or manufacturer. If the design free area of a louver is not known nor available, it shall be assumed that **wood** louvers will have **20-25** percent free area and **metal** louvers will have **60-75** percent free area as shown in the National Fuel Gas Code.*

3. If the heater room is located against an outside wall and air openings can communicate directly with the outdoors, the two openings on the out side wall must each have a net free area, in square inches as follows:

<u>Model</u>	<u>Sq. In. Of Free Area</u>
260/261	66
330/331	84
400/401	100

Location of the openings is the same as in the previous case - that is, within 12 inches of the top, and within 12 inches of the bottom of the enclosure. If horizontal ducts are used, the area must be doubled and the duct area shall not be less than the area of the openings they connect, and in no case shall the smallest dimension be less than 3 inches.

## OUTDOOR MODELS

Heaters must not be installed under an overhang of less than three (3) feet from the top on the heater. Three (3) sides must be open in the area under the overhang. Roof water drainage must be diverted away from the heater installed under overhangs with the use of gutters.

The point from where the flue products exit the heater must be a minimum of four (4) feet below, four (4) feet horizontally from or one (1) foot above any door, window or gravity inlet to a building. The top surface of the heater shall be at least three (3) feet above any forced air inlet, or intake ducts located within ten (10) feet horizontally.

In areas where high winds are frequent, it may be necessary to locate the heater a minimum of 3' from high vertical walls, or install a wind break so the heater is not in direct wind current.

## VENTING CONNECTIONS (Outdoor Models)

Outdoor vent top is shipped separately and must be installed on site.

### MODELS 260-401

- Step 1: Insert screw retainer clip over mounting flange, (4 places).

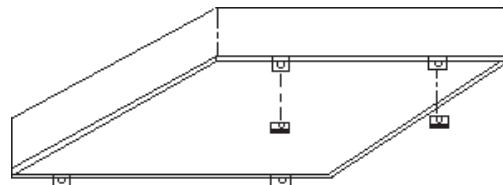

Fig. #8280.1

- Step 2: Attach mounting angles to heater jacket with 1/2" sheetmetal screws, (4 places).

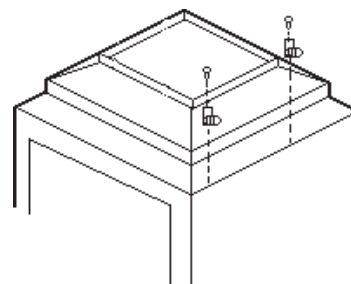
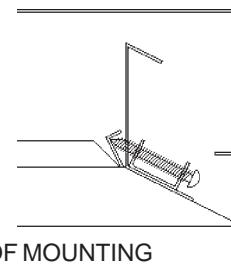

Fig. #8281.1

- Step 3: Lower outdoor top to heater and secure with 1" sheetmetal screws.



LONG SIDE OF MOUNTING ANGLE LOCATED AS SHOWN

## VENTING CONNECTIONS (Indoor Models)

The draft hood is shipped separately and must be installed on the heater.

For Model 260/261:

1. Mount draft hood on top of heater and attach with the 4 sheet metal screws provided. Draft hood should be positioned with the vent sensor located on the front left side as shown.
2. Remove plastic plug from left side of heater jacket and install plastic grommet provided.
3. Route flue sensor wire harness through the grommet installed in Step 2.

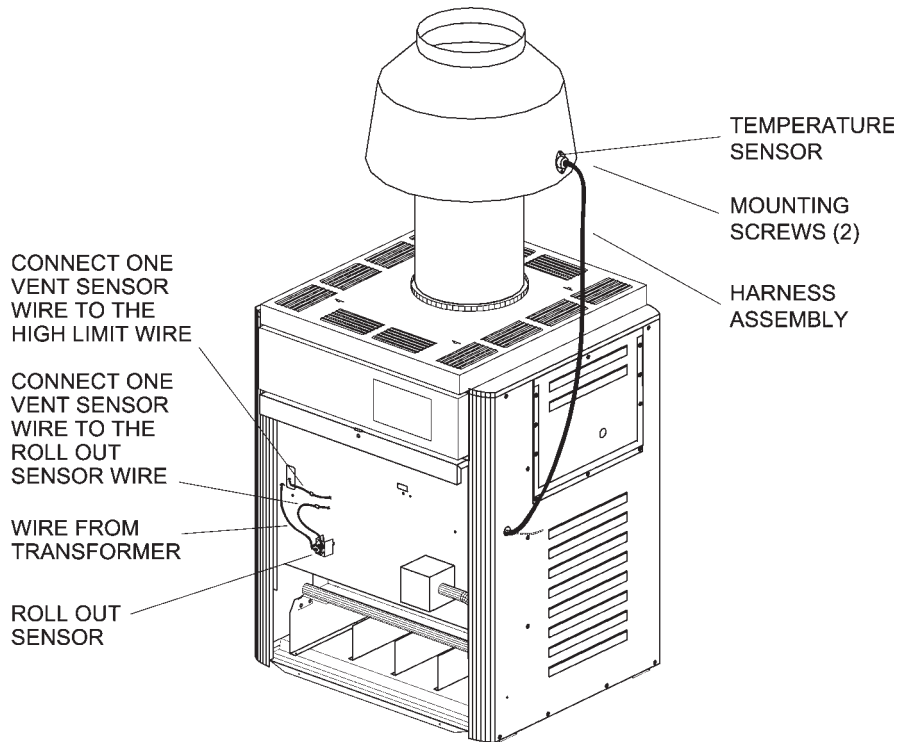
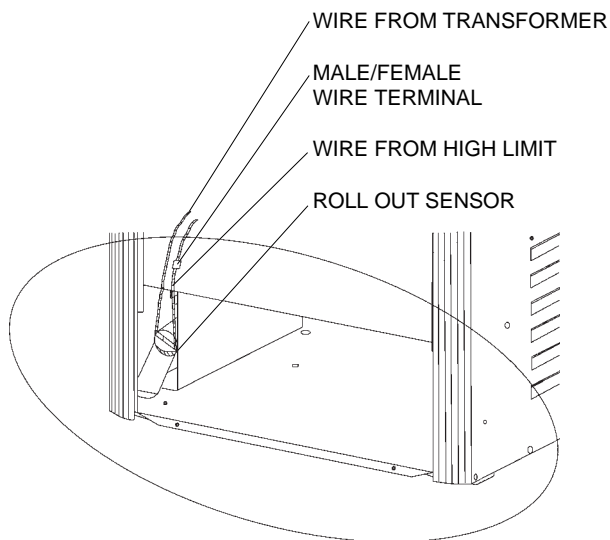

Fig. #9351

4. Remove door and locate wire from roll out sensor to Hi Limit with the male/female connector.



Before Installation of Draft Hood

Fig. #8947.2

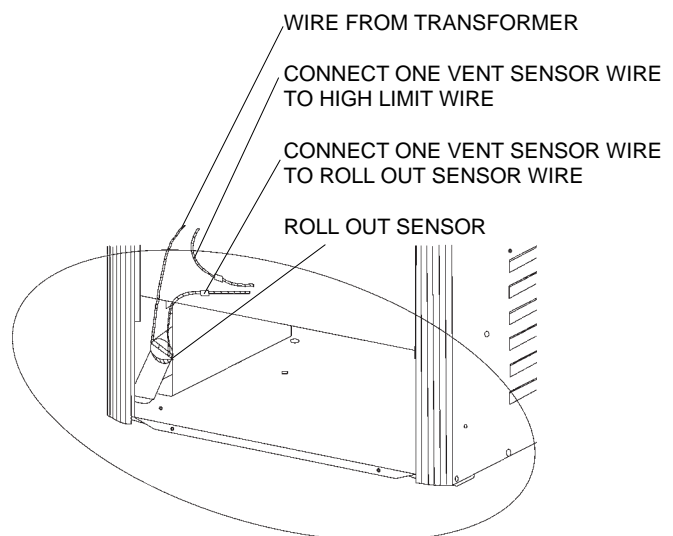

After Installation of Draft Hood

Fig. #8947.3

5. Disconnect male/female connector and attach to the 2 wires from draft hood vent sensor harness.



MODELS 330/331 AND 400/401  
VENT TERMINAL/INDOOR STACK INSTALLATION

1. Remove the louvered jacket top by removing four (4) #10 flat head screws.
2. If originally installed, remove "Pagoda" top from the louvered jacket top.
3. Place the inner stack adapter panel over the flue collector inside the heater. Make sure the flanged side of the flue opening is up.
4. Turn the stack (draft hood) up side down and set it down bottom side up.
5. Turn the jacket top panel (removed in step 1) up side down and place it through the stack.
6. Attach the three (3) mounting brackets to the stack using the screws provided and the holes that are pre-drilled in the stack. **Make sure the brackets are positioned with the flange near the top side of the stack (see illustration).**  
*Caution must be taken not to over tighten and strip the screw threads.*
7. Turn the assembled stack and jacket top, right side up. The jacket top will be trapped between the brackets and the top of the stack. Place the stack over the inner adapter panel flanged hole and lower the louvered jacket top panel back into its original position. Reinstall the four (4) green #10 flat head screws removed in step 1 above.

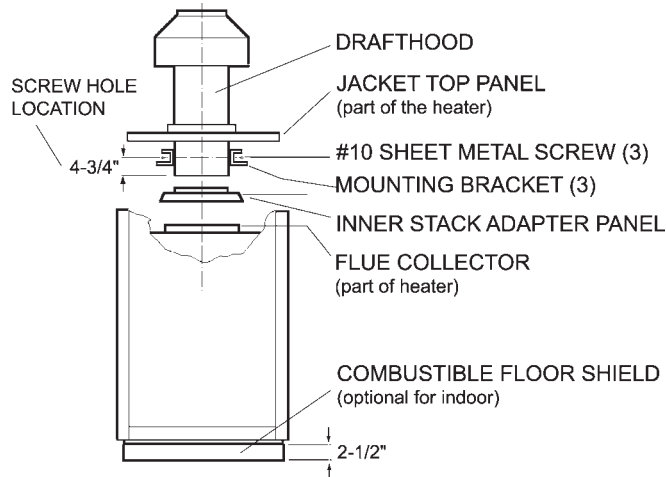

Fig. # 8246.6

**WARNING:** Indoor heater require a drafthood that must be connected to a vent pipe and properly vented to the outside. Failure to follow this procedure can cause fire or fatal carbon monoxide poisoning.

Vent piping the same size or larger than the draft hood outlet is recommended, however, when the total vent height is at least ten (10) feet (draft hood relief opening to vent terminal), the vent pipe size may be reduced as specified in the National Fuel Gas Code, ANSI Z223.1. As much as possible avoid long horizontal runs of vent pipe and too many elbows.

If installation requires horizontal runs, the vent pipe must have a minimum of 1/4 inch per foot rise and should be supported at not more than five foot intervals. Plumbers tape, crisscrossed, will serve to space both horizontal and vertical piping. Maximum vent connector horizontal length shall be 1-1/2 feet (18 inches) for each inch of connector diameter as follows:

Heater Size	Vent Connector Diameter	Max Horizontal Length - FT
260/261	8"	12.0
330/331	9"	13.5
400/401	10"	15.0

Gas vents supported only by the flashing and extending above the roof more than five feet should be securely guyed or braced to withstand snow and wind loads. We recommend use of insulated vent pipe spacer through the roofs and walls.

For protection against rain or blockage by snow, the vent pipe must terminate with a listed vent cap which complies with the local codes or, in the absence of such codes, to the latest edition of the National Fuel Gas Code, **ANSI Z223.1**.

The discharge opening must be a minimum of two feet vertically from the roof surface and at least two(2) feet higher than any part of the building within ten (10) feet. Vent stack shall be at least five (5) feet in vertical height above the drafthood outlet. The vent cap location shall have a minimum clearance of four (4) feet horizontally from, and in no case above or below, unless a 4-foot horizontal distance is maintained, from electric meters, gas meters regulators and relief equipment.

The weight of the vent stack or chimney must not rest on boiler draft hood. Support must be provided in compliance with applicable codes. The heater top and draft hood must be readily removable for maintenance and inspection. Vent pipe should be adequately supported to maintain proper clearances from combustible construction.

Type "B" double wall or equivalent vent pipe is recommended. However single wall metal vent pipe may be used as specified in the latest edition of the National Flue Gas Code **ANSI Z223.1**.

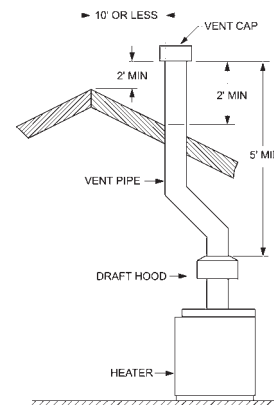

Fig. #8119.2

**WARNING:** These heaters must not be connected into any portion of mechanical draft systems operating under positive pressure. To do so may cause the flue products to be discharged into the living space causing serious health injury.

For connections to gas vents or chimneys, vent installations shall be in accordance with Part 7, Venting of Equipment, of the National Fuel Gas Code, **ANSI Z223.1**, or applicable provisions of the local building codes.

**COMMON VENTS**

Manifolds that connect more than one heater to a common chimney must be sized to handle the combined load. Consult available guides for proper sizing of the manifold and the chimney. At no time should the area be less than the area of the largest outlet.

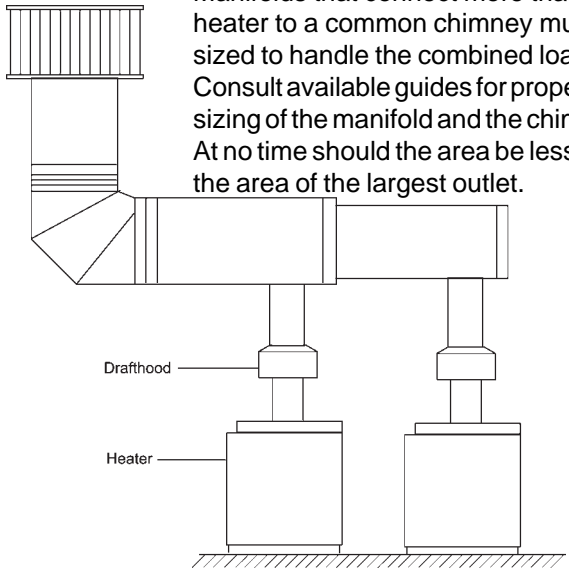

Fig. # 9463

At the time of removal of an existing heater, the following steps shall be followed with each appliance remaining connected to the common venting system placed in operation, while the other appliances remaining connected to the common venting system are not in operation.

- (a) Seal any unused openings in the common venting system.
- (b) Visually inspect the venting system for proper size and horizontal pitch and determine there is no blockage or restriction, leakage, corrosion and other deficiencies which could cause an unsafe condition.
- (c) Insofar as is practical, close all building doors and windows and all doors between the space in which the appliances remaining connected to the common venting system are located and other spaces of the building. Turn on clothes dryers and any appliance not connected to the common venting system. Turn on any exhaust fans, such as range hoods and bathroom exhausts, so they will operate at maximum speed. Do not operate a summer exhaust fan. Close fireplace dampers.
- (d) Place in operation the appliance being inspected. Follow the lighting instructions. Adjust tankstat so appliance will operate continuously.

- (e) Test for spillage at the draft hood relief opening after 5 minutes of main burner operation. Use the flame of a match or candle, or smoke from a cigarette, cigar or pipe to visually check spillage.
- (f) After it has been determined that each appliance remaining connected to the common venting system properly vents when tested as outlined above, return doors, windows, exhaust fans, fireplace dampers and any other gas burning appliance to their previous conditions of use.
- (g) Any improper operation of the common venting system should be corrected so the installation conforms with the latest edition of the National Fuel Gas Code, ANSI Z223.1. When re-sizing any portion of the common venting system, the common venting system should be re-sized to approach the minimum size as determined using the appropriate tables in Chapter 10 and in appendix G of the National Fuel Gas Code, ANSI Z223.1 and CAN/CSA-B149.1.

**GAS SUPPLY CONNECTIONS**

The inlet gas connection to the heater gas valve is 1/2" for model 203; 3/4" for models 260 and 330; and 1" for model 400. Provide an adequate gas supply line no smaller than 1/2", according to the chart below:

MAXIMUM EQUIVALENT PIPE LENGTH (FEET)  
 NATURAL GAS 1000 BTU/FT .60 SPECIFIC GRAVITY @ 0.5" W.C. PRESSURE DROP  
 PROPANE GAS 2500 BTU/FT 1.53 SPECIFIC GRAVITY @ 0.6" W.C. PRESSURE DROP

	1/2"		3/4"		1"		1-1/4"		1-1/2"	
	N	P	N	P	N	P	N	P	N	P
260/261	-	10	20	40	60	140	250	560	-	-
330/331	-	-	15	25	35	85	150	380	360	-
400/401	-	-	-	15	25	60	100	260	250	-

Gas piping must have a sediment trap ahead of the boiler gas controls, and a manual shut-off valve located outside the heater jacket. All gas piping should be tested after installation in accordance with local codes.

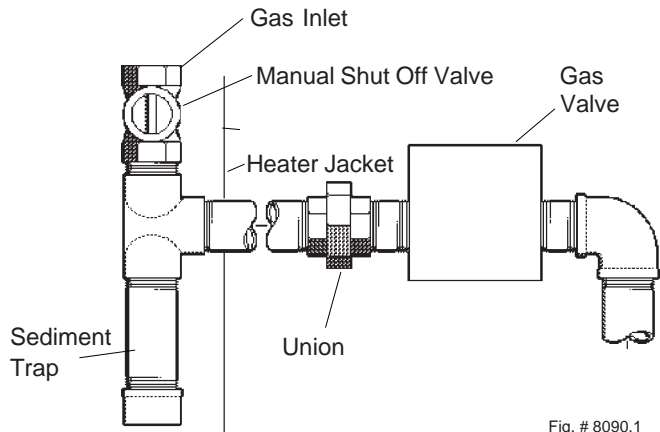

Fig. # 8090.1

**CAUTION:** The heater and its manual shut off valve must be disconnected from the gas supply during any pressure testing of that system at test pressures in excess of 1/2 PSIG(3.45 KPA). Dissipate test pressure in the gas supply line before reconnecting the heater and its manual shut off valve to gas supply line. FAILURE TO FOLLOW THIS PROCEDURE MAY DAMAGE THE GAS VALVE. OVER PRESSURED GAS VALVES ARE NOT COVERED BY WARRANTY. The heater and its gas connections shall be leak tested before placing the appliance in operation. Use soapy water for leak test DO NOT use open flame.

**NOTE:** Do not use teflon tape on gas line pipe thread. A flexible sealant suitable for use with Natural and Propane gases is recommended.

### GAS PRESSURE-SPECIFICATIONS

	Inches	W.C.	Regulator
	Min.	Max.	Setting
Natural	7.0	10.5	4.0
Propane	12.0	13.0	11.0

Note: Do not exceed maximum inlet gas pressure. The minimum value shown is for input adjustment.

### GAS PRESSURE REGULATOR

The gas valve is provided with pressure taps to measure gas pressure upstream of the gas valve and downstream which is the same as the manifold pressure.

The gas pressure regulator is preset and sealed at 4" W.C. for natural gas, and 11" W.C. for propane gas. Between the gas valve and the burners is a 1/8" pipe plug. The pressure at this point, taken with a manometer, should be about 3.7" W.C. natural gas and 10.5" W.C. propane gas. Lo NOx models should be 3.9" W.C. natural gas only. If an adjustment is needed, remove seal and turn adjustment screw clockwise ↻ to increase pressure or counterclockwise ↻ to decrease pressure.

### WATER CONNECTIONS & SYSTEM PIPING

The pipe size and fittings between the heater and the tank should be at least 1-1/2" for all models. The tank should be located as close to the heater as possible, as shown in the drawing below:

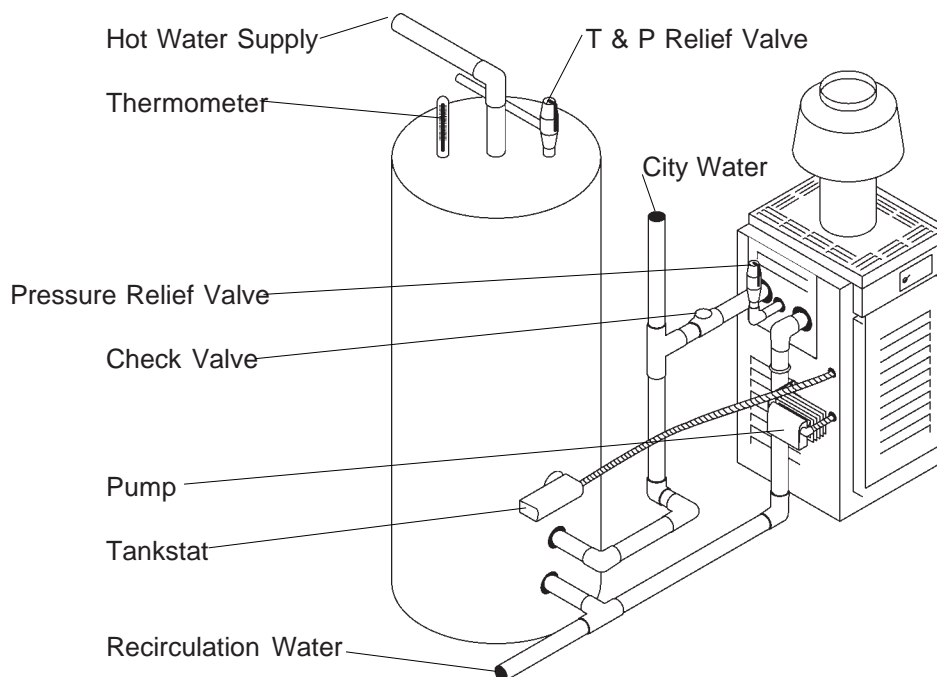

Fig. #9166

If this water heater is installed in a closed water supply system, such as one having a back-flow preventer in the cold water supply line, means shall be provided to control thermal expansion. Contact the water supplier or local plumbing inspector on how to control this situation.

When this water heater system is supplying general purpose hot water requirements for use by individuals, a thermostatically controlled mixing valve is recommended to reduce the risk of scald injury. Contact a licensed plumber or the local plumbing authority for further information.

Thermometer(s) should be installed so that they indicate the water temperature at or near the outlet of the storage tank.

### RELIEF VALVE

A new combination temperature and pressure (T & P) relief valve, complying with the Standard for Relief Valves and Automatic Gas Shut Off Devices for Hot Water Supply Systems, ANSI Z21.22, must be installed in the opening provided on top of the storage tank, at the time of installation. No valve is to be placed between the relief valve and the storage tank.

The pressure rating of the relief valve must not exceed the 160 maximum working pressure indicated on the water heater rating plate. The BTUH rating of the relief valve must not be less than the BTUH input of the heater.

Connect the outlet of the relief valve to a suitable open drain. The discharge line must pitch downward from the valve to allow complete draining (by gravity) of the relief valve and discharge line. The discharge line should be no smaller than the outlet of the valve. The end of the discharge line should not be threaded or concealed, and should be protected from freezing. No valve of any type, restriction or reducer coupling, should be installed in the discharge line. Local codes shall govern installation of relief valve.

---

## 261 LOW NO<sub>x</sub> WH1

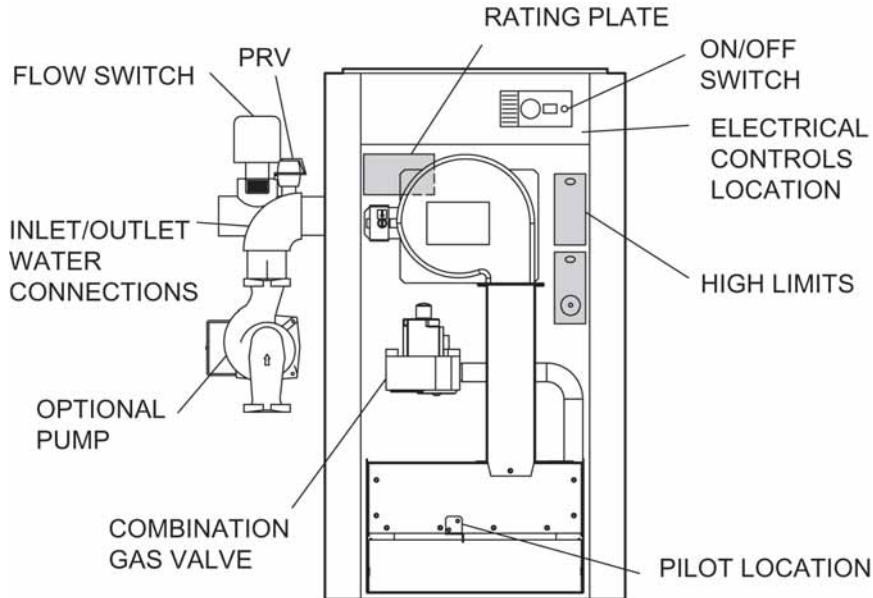

Fig # 9360

## ELECTRICAL WIRING

The electrical power supply requirement for these heaters is 115 volts, 60 Hz. Field wiring connections and electrical grounding must comply with the local codes, or in the absence of local codes, with the latest edition of the National Electrical Code, **ANSI/NFPA 70**. Provide a separate fused circuit from the main electrical panel to the heater, and a disconnecting means within sight of the heater.

Remove the control box cover and make the power supply connections in the field wiring compartment. The pump is supplied and factory wired to operate with the heater. The current draw is approximately 2.0 amps. Refer to the heater internal wiring diagrams shown on pages 13 to 15.

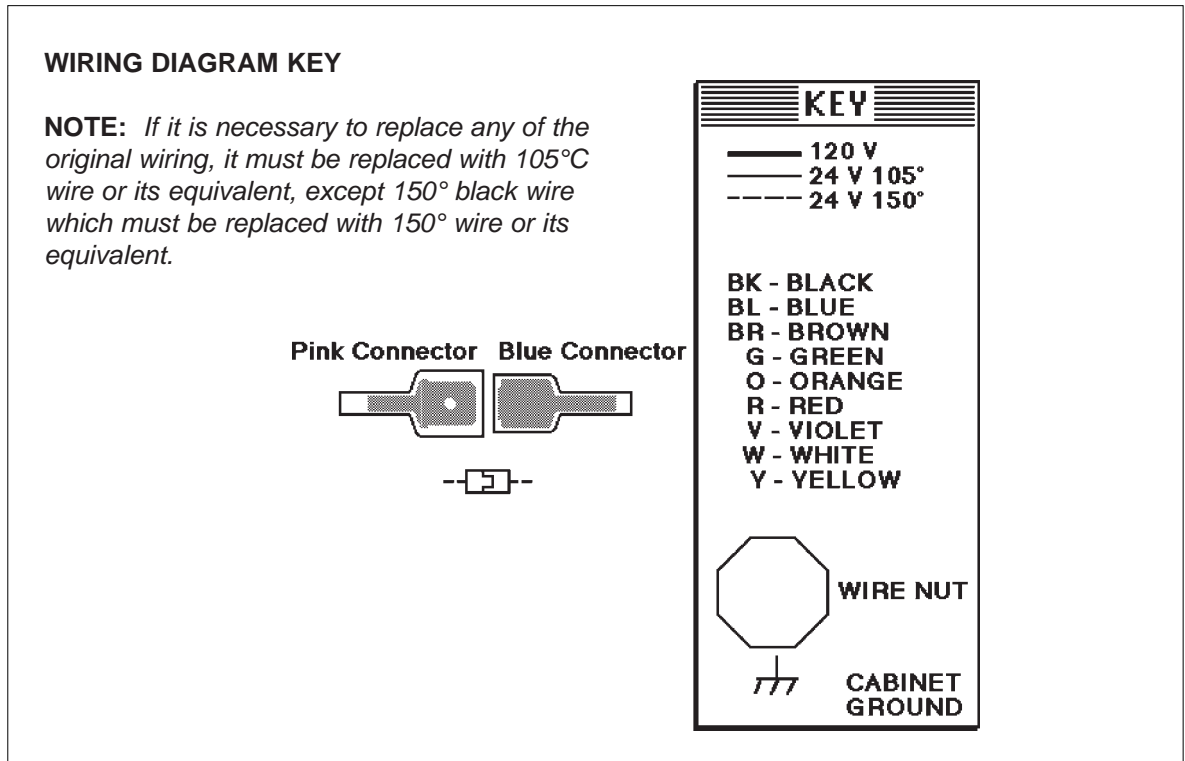

Fig. #8096.2

**WIRING DIAGRAM: STANDING PILOT  
MODELS 260 - 400**

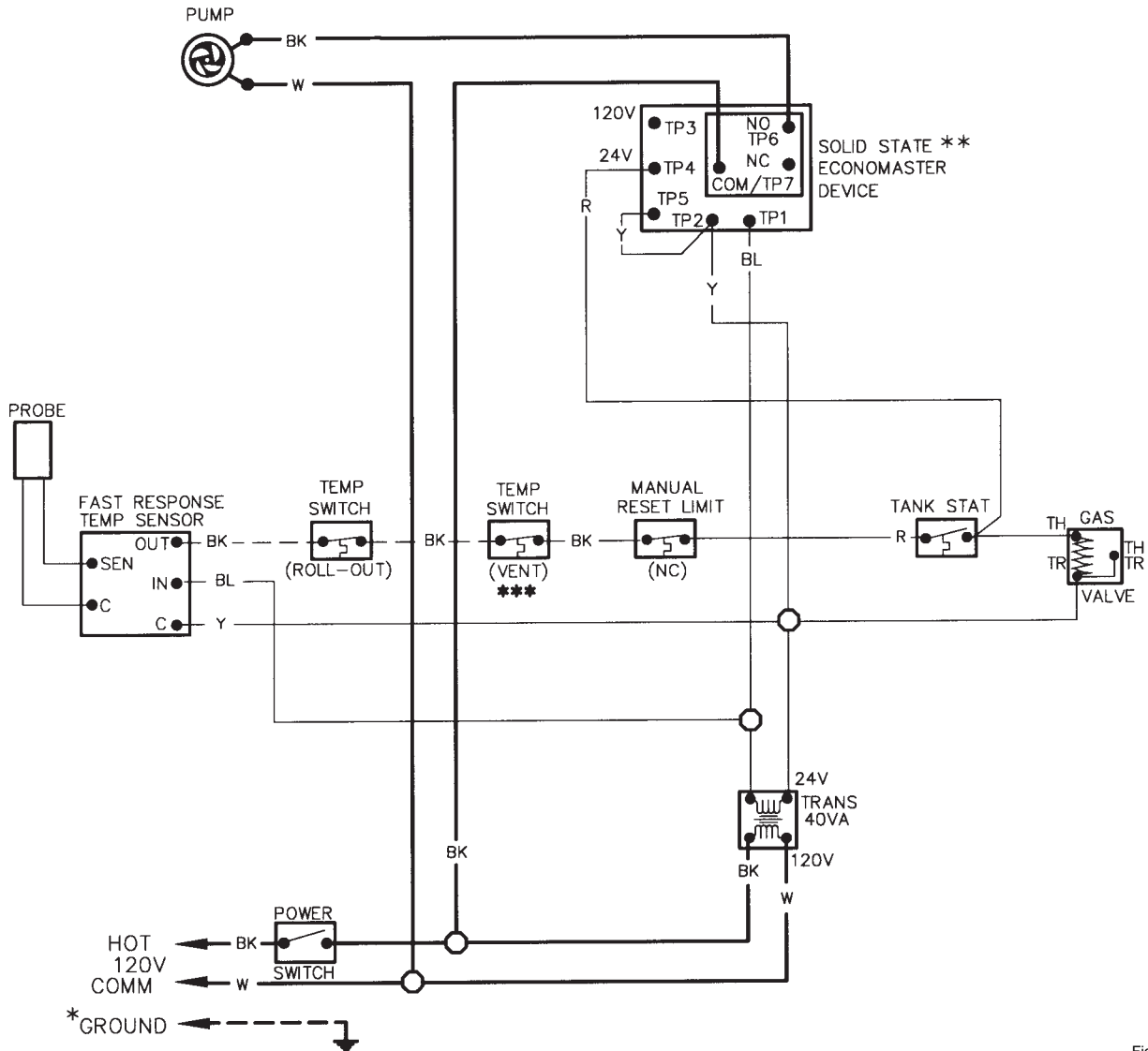

Fig. #2372

**NOTES:**

\* USE GROUND CLIP PROVIDED.

\*\* PUMP DELAY ADJUSTABLE BETWEEN 3 AND 10 MINUTES.

\*\*\* VENT TEMP SWITCH PROVIDED ONLY ON INDOOR HEATERS.

ROLL-OUT AND VENT SWITCHES NOT REQUIRED ON MODELS 330 AND 400.



**WIRING DIAGRAM: INTERMITTENT IGNITION DEVICE (IID)  
MODEL 260**

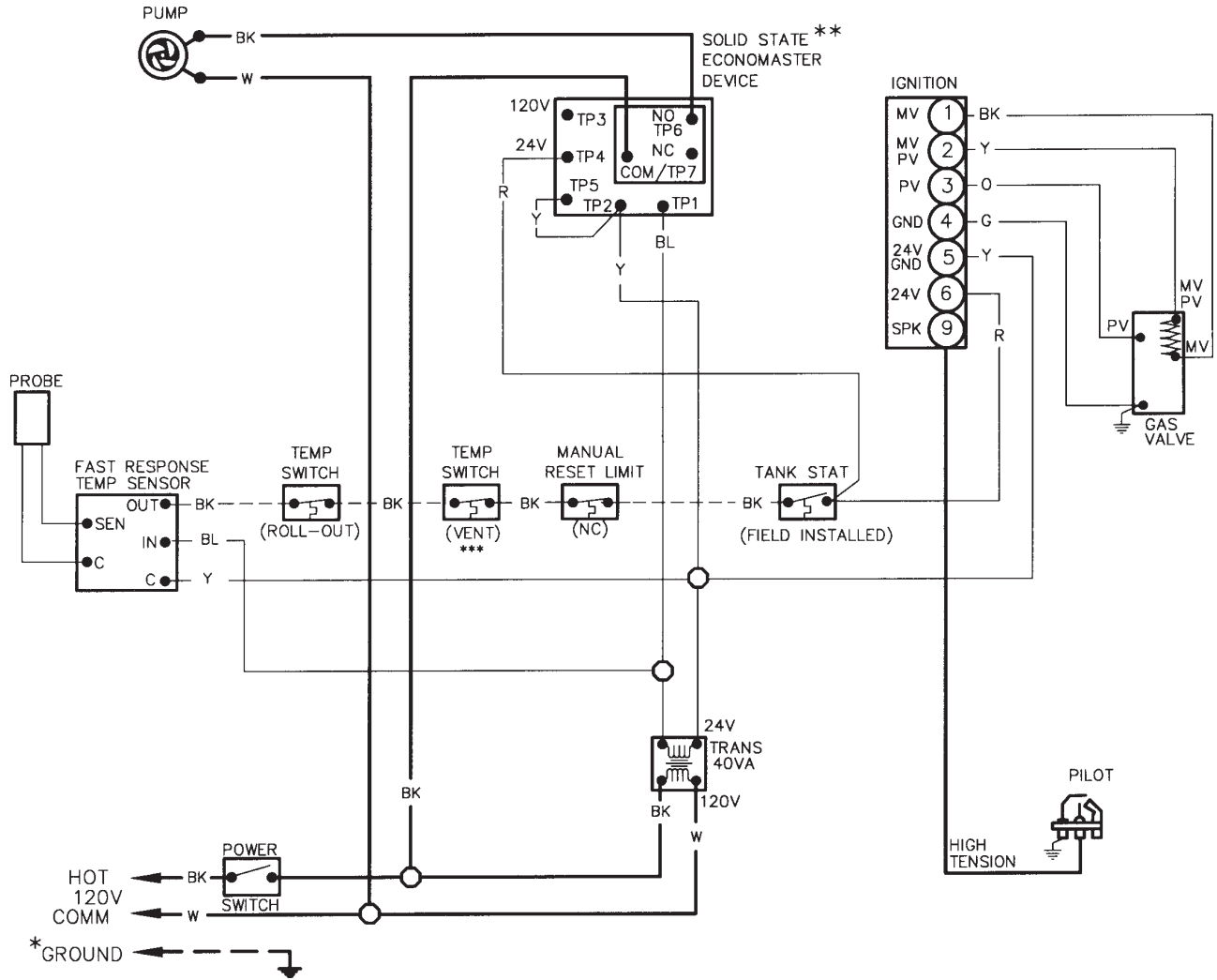

Fig. #2373

**NOTES:**

\* USE GROUND CLIP PROVIDED. FAILURE TO PROVIDE PROPER GROUND MAY RESULT IN LOCK-OUT.

\*\* PUMP DELAY ADJUSTABLE BETWEEN 3 AND 10 MINUTES.

\*\*\* VENT TEMP SWITCH PROVIDED ONLY ON INDOOR HEATERS.

**WIRING DIAGRAM: INTERMITTENT IGNITION DEVICE (IID)  
MODELS 330 & 400**

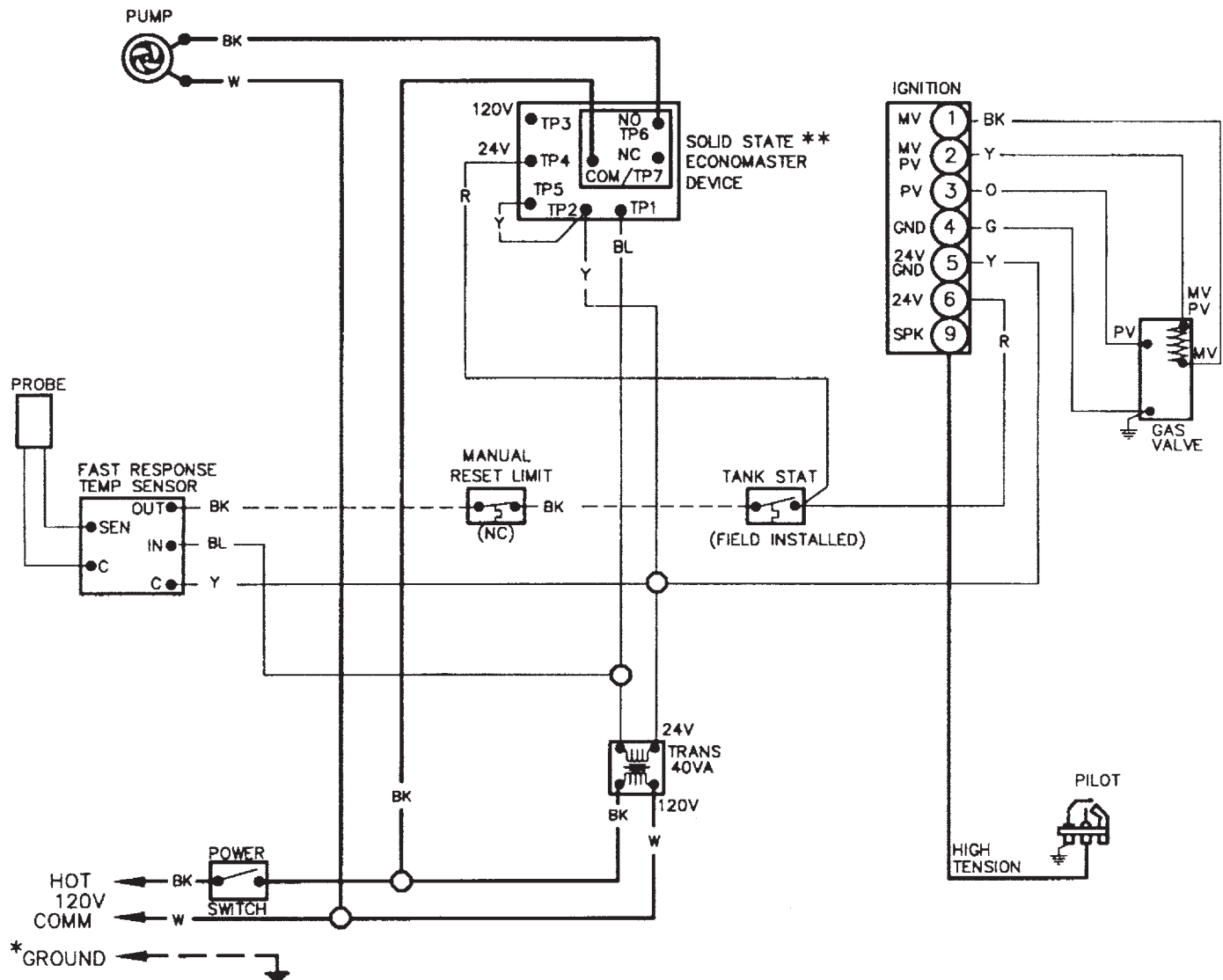

**NOTES:**

\* USE GROUND CLIP PROVIDED. FAILURE TO PROVIDE PROPER GROUND MAY RESULT IN LOCK-OUT.

\*\* PUMP USED MUST BE RATED 10 AMPS MAX OR 3/4 HP MAX.  
PUMP DELAY ADJUSTABLE BETWEEN 3 AND 10 MINUTES.

**WIRING DIAGRAM: INTERMITTENT IGNITION  
DEVICE (IID)  
MODEL 261 LOW NO<sub>x</sub>**

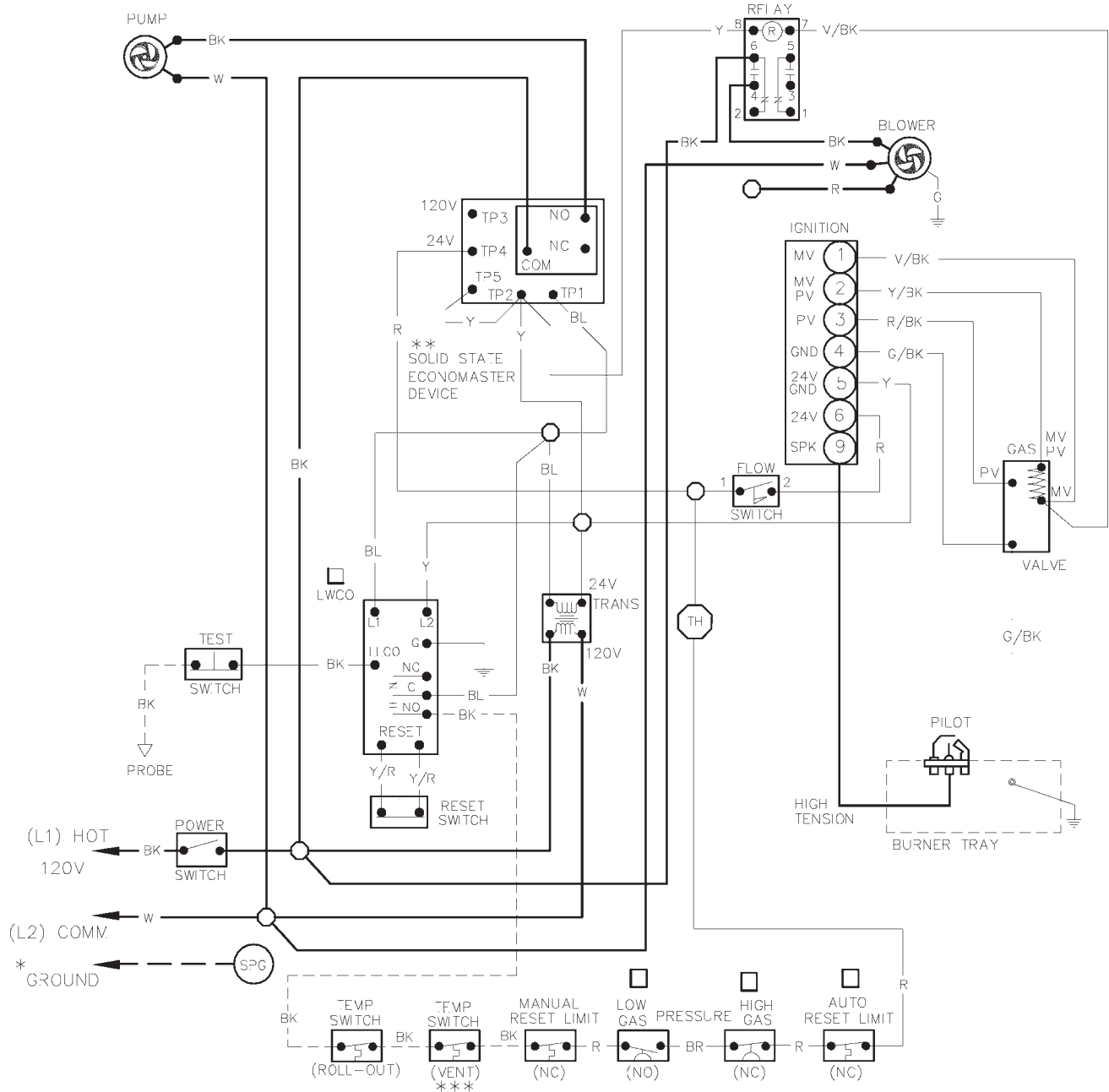

**NOTES:**

- \* USE GROUND LUG PROVIDED. FAILURE TO PROVIDE PROPER GROUND MAY RESULT IN LOCK-OUT ALL GROUND  $\neq$  TERMINATE AT (SPG).
- \*\* PUMP USED MUST BE RATED 10 AMPS MAX OR 3/4 HP MAX. PUMP DELAY ADJUSTABLE BETWEEN 3 AND 10 MINUTES.
- \*\*\*VENT TEMP SWITCH ONLY PROVIDED ON INDOOR UNITS

**WIRING DIAGRAM: INTERMITTENT IGNITION  
DEVICE (IID)  
MODEL 401 LOW NO<sub>x</sub>**

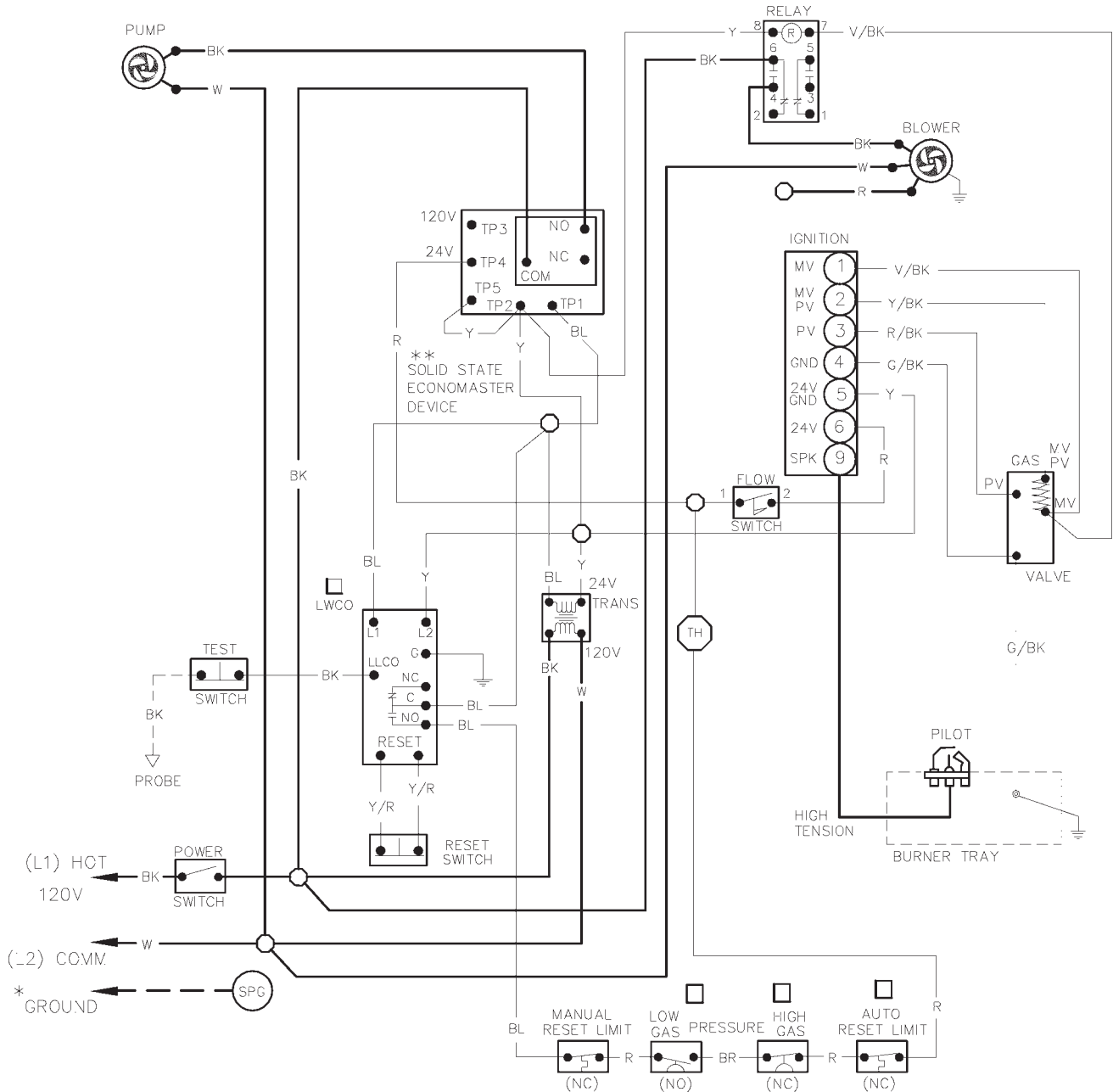

**NOTES:**

- \* USE GROUND LUG PROVIDED. FAILURE TO PROVIDE PROPER GROUND MAY RESULT IN LOCK-OUT ALL GROUND  $\equiv$  TERMINATE AT (SPG).
- \*\* PUMP USED MUST BE RATED 10 AMPS MAX OR 3/4 HP MAX. PUMP DELAY ADJUSTABLE BETWEEN 3 AND 10 MINUTES.

## 4. SERVICING PROCEDURES

### SEQUENCE OF OPERATION

#### INTERMITTENT IGNITION DEVICE (IID)

Heaters equipped with the IID system will automatically light the pilot burner first and then the main burner, each time there is a call for heat from the tankstat. Whenever the tankstat calling for heat, the circulator supplied with the heater, will be energized and should be running. The ignition control module will also be energized to initiate the pilot ignition by opening the first main valve (pilot). At the same time, the electronic spark generator in the module produces a high voltage spark pulse output that lights the pilot burner. If the pilot burner does not light, the module will not energize the second main valve and the burners will not light. Ignition spark continues only until the timed trial for ignition period ends. Then, the module goes into safety shutdown or lockout. Lockout de-energizes the first main valve operator and closes the first main (pilot) valve in the gas control, stopping pilot gas flow. The ignition control system must be reset by setting the tankstat below water temperature for one minute or by turning off power to the module for one minute. When the pilot flame is established, flame rectification circuit is completed between the sensor and burner ground. The flame sensing circuit in the module detects the flame current, shuts off the spark generator and energizes the second main valve operator which opens the second main valve. This allows gas to flow to the burners where it is ignited by the pilot burner flame. When the tankstat is satisfied, the valve operators are de-energized shutting off the pilot and main burners, and also the circulator.

### START-UP PROCEDURES

#### SECTION 1. Filling the System

Fill system with water. Purge all air from the system using purge valve sequence. After system is purged of air, lower system pressure.

Flush system before putting into operation to assure that foreign material does not damage pump seals.

#### SECTION 2. Checking the Circulator

Before lighting the heater and after system is filled, make sure that circulator is operating properly. Manual gas valve should be off.

**NOTE:** *Circulator motor supplied with the heater does not require lubrication.*

#### SECTION 3. Lighting the Heater

For your safety read carefully before proceeding to light the heater.

**CAUTION:** *Liquefied petroleum gas is heavier than air and sinks to the ground. Exercise extreme care in lighting heater in confined areas.*

#### For Standing Pilot Models

**WARNING:** *If you do not follow these instructions exactly, a fire or explosion may result causing property damage, personal injury or loss of life.*

- A. This heater has a pilot which must be lighted by hand. When lighting the pilot, follow these instructions exactly.
- B. **BEFORE LIGHTING** smell all around the heater area for gas. Be sure to smell next to the floor because some gas is heavier than air and will settle on the floor.

**WHAT TO DO IF YOU SMELL GAS**

- Do not try to light any appliance.
- Do not touch any electric switch.
- Do not use any phone in your building.
- Immediately call your gas supplier from a neighbor's telephone. Follow the gas supplier's instructions.
- If you cannot reach your gas supplier, call the fire department.

- C. Use only your hand to push in, move or turn the gas control knob or lever. Never use tools. If the knob or lever will not push in, move or turn by hand, don't try to repair it, call a qualified service technician. Force or attempted repair may result in a fire or explosion.
- D. Do not use this heater if any part has been under water. Immediately call a qualified service technician to inspect the heater and to replace any part of the control system and any gas control which has been under water.

**FOR STANDING PILOT MODEL WITH ROBERTSHAW GAS VALVE, ON/OFF OPERATION**

1. **STOP!** Read the safety information above.
2. Set the tankstat on the lowest setting.
3. Turn OFF all electric power to the heater.
4. Remove heater door panel.
5. Push in gas control knob slightly and turn clockwise to "OFF".

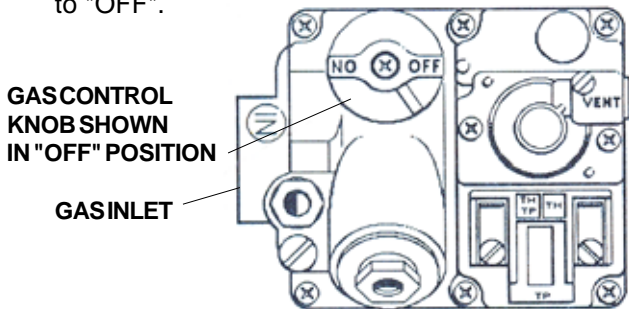

**NOTE:** Knob cannot be turned from "PILOT" to "OFF" unless knob is pushed in slightly. Do not force.

6. Wait five (5) minutes to clear out any gas. Then smell for gas, including near the floor. If your smell gas, STOP! Follow "B" in the safety information above on this label. If you don't smell gas, go to the next step.
7. Locate pilot mounted on the right side of the burner drawer, right of first burner.
8. Turn knob on gas control counterclockwise to "Pilot".

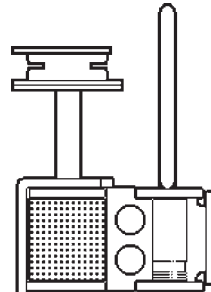

Fig.#8083.2

**HONEYWELL PILOT**

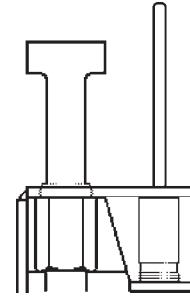

Fig.#8041.2

**ROBERTSHAW PILOT**

9. Push in control knob all the way and hold in, immediately light the pilot with a match. Continue to hold control knob in for about one minute after the pilot is lighted, release knob and it will pop back up. Pilot should remain lighted. If it goes out, repeat steps 4 through 8.
  - \* If knob does not pop up when released, stop and immediately call your service technician or gas supplier.
  - \* If the pilot does not stay lit after several tries, turn the gas control knob to "OFF" and call your service technician or gas supplier.
10. Stand to the side of the heater and turn the gas control knob counterclockwise to "ON".
11. Replace heater door.
12. Turn "ON" all electrical power to the heater.
13. Set the tankstat to the desired setting.

**FOR STANDING PILOT MODEL WITH HONEYWELL GAS VALVE, ON/OFF OPERATION**

1. **STOP!** Read the safety information.
2. Set the tankstat to the lowest setting.
3. Turn Off all electrical power to the heater.
4. Remove heater door panel.
5. Turn gas control knob clockwise to "OFF".

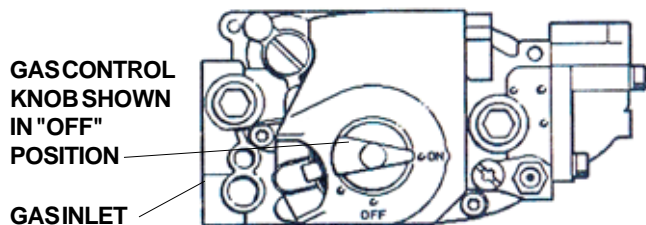



6. Wait five (5) minutes to clear out any gas. Then smell for gas, including near the floor. If you smell gas, STOP! Follow "B" in the safety information above on this label. If you don't smell gas, go to the next step.
7. Locate pilot mounted on the right side of the burner drawer, right of first burner.
8. Turn knob on gas control counterclockwise to "PILOT".
9. Push down and hold the red reset button in, immediately light the pilot with a match. Continue to hold down red reset button for about one minute after the pilot is lighted. Release red reset button and it will pop back up. Pilot should remain lighted. If it goes out, repeat steps 4 through 8.
  - \* If red reset button does not pop up when released, STOP and immediately call your service technician or gas supplier.
  - \* If the pilot does not stay lit after several tries, turn the gas control knob to "OFF" and call your Service technician or gas supplier.
10. Stand to the side of the heater and turn the gas control knob counterclockwise ↶ to "ON".
11. Replace heater door.
12. Turn "ON" all electrical power to the heater.
13. Set the tankstat to the desired setting.

#### SYSTEM SHUTDOWN PROCEDURE

1. Set the tankstat to "OFF" or the lowest setting.
2. Turn off all electric switches to the heater.
3. Turn off all gas valves supplying gas to the heater. Refer to operating instruction label on the heater.
4. Shut off the water supply to the heater piping system loop.
5. Open drain valve on the tank to remove water from the heater and the piping circuits.

#### FOR AUTOMATIC IGNITION MODELS.

Please read carefully and understand the following safety information before operating the heater.

**WARNING:** *If you do not follow these instructions exactly, a fire or explosion may result causing property damage, personal injury or loss of life.*

- A. This heater is equipped with an ignition device which automatically lights the pilot. Do not try to light the pilot by hand.
- B. **BEFORE OPERATING** smell all around the heater area for gas. Be sure to smell next to the floor because some gases are heavier than air and will settle on the floor.

#### WHAT TO DO IF YOU SMELL GAS

- Do not try to light any appliance.
- Do not touch any electric switch;

- Do not use any phone in your building.
- Immediately call your gas supplier from a neighbor's phone. Follow the gas supplier's instructions.
- If you cannot reach your gas supplier, call the fire department.

- C. Use only your hand to push in, move or turn the gas control knob or lever. Never use tools. If the knob or lever will not push in, move or turn by hand don't try to repair it, call a qualified service technician. Force or attempted repair may result in a fire or explosion.
- D. Do not use this heater if any part has been under water. Immediately call a qualified service technician to inspect the heater and to replace any part of the control system and any gas control which has been underwater.

#### FOR INTERMITTENT IGNITION (IID) WITH HONEYWELL OR ROBERTSHAW GAS VALVE

1. STOP! Read the safety information above on this label.
2. Set the tankstat on the lowest setting.
3. Turn off all electric power to the appliance.
4. This appliance is equipped with an ignition device which automatically lights the pilot. Do not try to light the pilot by hand.
5. Remove heater door panel.
6. **For Robertshaw Gas Valve:** Turn gas control knob clockwise ↷ to "OFF".

**For Honeywell Gas Valve:** Turn gas control knob clockwise ↷ to "OFF". Make sure knob rest against stop.

**For Honeywell Gas Valve:** (Models 400)

Push in gas control knob slightly and turn clockwise to "OFF". Knob cannot be turned to "OFF" unless knob is pushed in slightly. Do not force.

7. Wait five (5) minutes to clear out any gas. Then smell for gas, including near the floor. If you smell gas, STOP! Follow "B" in the safety information previously stated. If you do not smell gas, go to the next step.
8. **For Robertshaw Gas Valve:** Turn gas control knob counterclockwise ↶ to "ON".

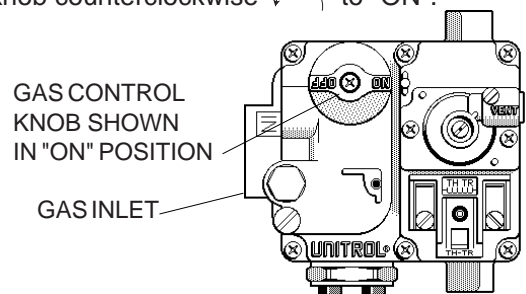



Fig. #8080

**For Honeywell Gas Valve:** Turn gas control knob counter clockwise  from "OFF" until it stops. Push in gas control knob and continue rotating counter clockwise  to "ON" position. Make sure knob rest against stop.

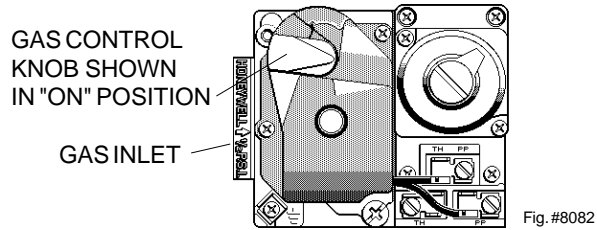



Fig. #8082

**For Honeywell Gas Valve: (Models 403)**

Turn gas control knob counter clockwise  to "ON".

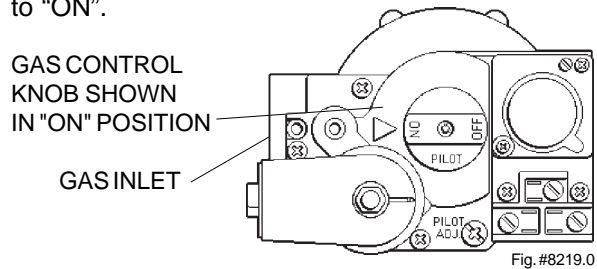



Fig. #8219.0

9. Replace door panel.
10. Turn on all electric power to the appliance.
11. Set tankstat to desired setting.
12. If the appliance will not operate, follow the instructions "To Turn Off Gas To Appliance" and call your service technician or gas supplier.

#### TO TURN OFF GAS TO APPLIANCE

1. Set the thermostat to the lowest setting.
2. Turn off all the electric power to the appliance if service is to be performed.
3. Remove door panel.
4. **For Robertshaw Gas Valve:** Turn gas control knob clockwise  to "OFF".

**For Honeywell Gas Valve:** Turn gas control knob clockwise  to "OFF". Make sure knob rest against stop.

**For Honeywell Gas Valve: (Models 403)**

Push in gas control knob slightly and turn clockwise  to "OFF".

5. Replace heater door panel.

#### SECTION 4. Testing the Ignition Safety Shut-off

The ignition system safety shutoff must be tested by conducting the following method of tests:

##### For Standing Pilot Systems

- a. With the main burners on, remove the pilot adjustment cover screw.
- b. Insert a small slot screw driver and turn the adjustment screw clockwise  until pilot flame goes out. Note and count number of turns made.
- c. Gas valve will shut off main burners after about three (3) minutes. End of test. If the gas valve

will not shut off, follow the instructions "To Turn Off Gas To Heater" and call service technician or your gas supplier.

- d. Return pilot adjustment screw counterclockwise , same number of turns as in step (b).
- e. Replace pilot adjustment cover screw, then follow the lighting instructions to get heater ready for operation.

#### FOR AUTOMATIC IGNITION SYSTEMS

##### A. Intermittent Ignition (IID)

1. Turn on power to the ignition systems and turn gas supply off at the gas valve.
2. Check ignition module as follows:
  - a. Set the tankstat to high setting.
  - b. Watch for continuous spark at the pilot burner.
  - c. Time the spark operation. Time must be within the lockout timing period (15 or 90 seconds).
  - d. Turn tankstat down to end call for heat and wait 60 seconds on lockout models before beginning step 3.
3. Turn on gas supply.
4. Set tankstat to high setting.
5. Systems should start as follows:
  - a. Spark will turn on and pilot gas valve will open at once. Pilot burner should ignite after gas reaches the pilot burner.
  - b. Spark ignition should cut off when pilot flame is established.
  - c. Main gas valve should open and main burner should ignite after gas reaches the burner port.

#### INSPECTION PROCEDURES

##### BURNERS

Clean main burners and air louvers of dust, lint and debris. Keep heater area clear and free from combustibles and flammable liquids. Do not obstruct the flow of combustion and ventilating air. Make visual check of burner and pilot flame. Yellow flame indicates clogging of air openings. Lifting or blowing flame indicates excess high gas pressure. Low flame indicates low gas pressure.

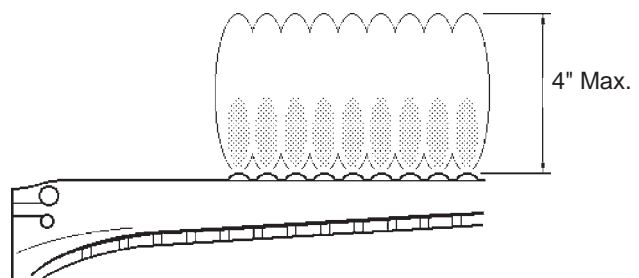

TYPICAL MAIN BURNER FLAME

Fig. #8144

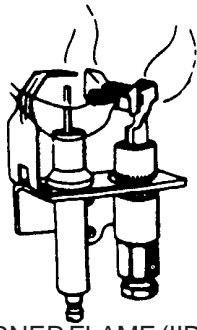

PILOT BURNER FLAME (IID UNITS)

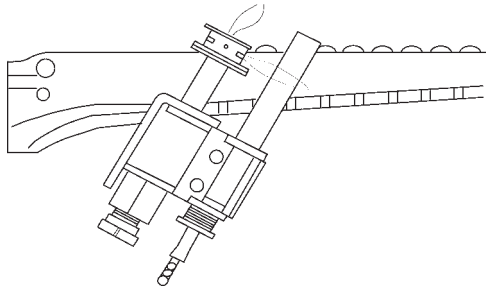

PILOT BURNER FLAME (STG PILOT UNITS)

#### CONTROLS

Check all controls to see that they are operational. To check electronic safety (IID Models), turn off main burner. Observe pilot burner when shutting off pilot gas. Ignition spark should go on. Main gas valve will also drop out.

High Limit Switch - to check high limit switch, turn dial setting down to a point slightly below the temperature of the water leaving the heater. The reset button should snap out and the burner should shut off. Reset dial to 30°F to 40°F above desired operating temperature, and push reset button. Burner should light.

#### LOW NO<sub>x</sub> HEATERS Sizes 181 to 401

The Raypak Low Nox Heater is offered as a model W1-ON-OFF firing.

The boilers are certified and tested under the ANSI Z21.10.3 Standards for hot water heaters.

The boiler should be installed to meet all local codes, the National Fuel Gas Code Z223.1 and with the National Electrical Code, ANSI/NFPA 70.

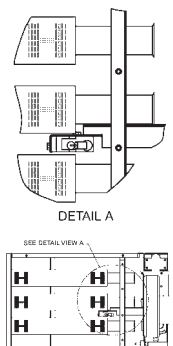

Fig # 9361

#### OPERATION

On call for heat, the ignition system, consisting of an electronic spark module, gas pilot system is energized. Providing pilot is proven blower will start running, the main gas valve will open and the boiler will operate. When the operating control is satisfied the boiler will shut down.

#### START-UP PROCEDURES (S8610B)

1. Turn on power to the boiler with gas supply off.
2. Check ignition module as follows:
  - a. Set the thermostat or controller to call for heat.
  - b. Watch for continuous spark at the pilot burner.
  - c. Check the ignition spark operation. Time must be within the lockout timing period (15 or 90 seconds).
  - d. Turn control down to end call for heat and wait 60 seconds on lockout models before beginning step 3.
3. Turn on gas supply.
4. Set controller to call for heat.
5. System should start as follows:
  - a. Spark will turn on and pilot gas valve will open and the blower will begin running.
  - b. Heater will operate until call for heat is satisfied.

#### BURNER ADJUSTMENT

This burner assembly does not require any primary air adjustments.

#### VISUAL INSPECTION

Flame can be observed through the slot opening above the plenum. Flame color is blue and evenly spread on the top surface of the burner. At least every three months a visual inspection should be made of the burners. In case flame lifting is observed on the burner, check gas pressure on manifold and static pressure in plenum. Gas pressure in manifold should be 3.9" W.C. and static pressure in plenum should be greater than 0.5" W.C.

#### ELECTRICAL

Be sure that electrical service to the boiler has proper overload fuse or circuit breaker protection, wire size and connections which comply with all applicable codes.

#### HIGH GAS PRESSURE SWITCH

Pressure switch senses high pressure and automatically shuts down burner if abnormal pressure exists.

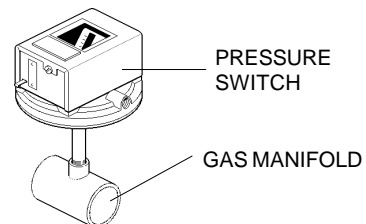
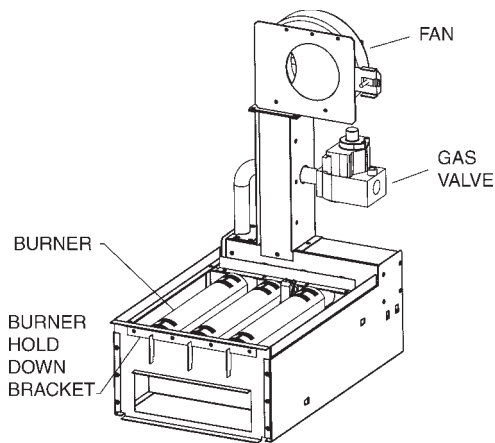

Fig. #8236.0



LOW NOx BURNER TRAY ASSEMBLY

### BURNER DRAWER REMOVAL

1. Shut off main electrical power switch to heater.
2. Shut off gas upstream of heater.
3. Remove front door.
4. Disconnect gas line from gas valve.
5. Remove (2) screws that mount burner tray to unit, and (4) screws that secure gas valve to jacket.
6. Disconnect wires that terminate at gas valve.
7. Unscrew (4) screws that secure the control box.
8. Disconnect pilot wire from the ignition module.
9. Disconnect wire harness from the combustion blower.
10. Carefully slide out the burner tray assembly.
11. Reverse above procedure to reinstall.

### GAS VALVE REMOVAL

1. Shut off main electrical power switch to heater.
2. Shut off gas supply to the heater.
3. Remove front door.
4. Disconnect gas line from gas valve.
5. Disconnect wires, pilot tubing and bleed line, if required.
6. Remove (2) screws that secure gas valve to jacket.
7. Turn vertical gas pipe from manifold slightly and unscrew gas valve.
8. Reverse above procedure to re-install.

### MAIN BURNER AND ORIFICE REMOVAL

1. Remove burner drawer. See burner drawer removal procedure.
2. Remove (8) screws from the hold down brackets.
3. Remove (8) screws from the left and right sides of the Manifold assembly. Detach the manifold assembly from the burner tray assembly.
4. Use a long ½" socket wrench to remove orifices from the gas manifold.
5. Remove burners by raising the bracket on the back end of the burners up and out of their slots.
6. Reverse above procedure to re-install.

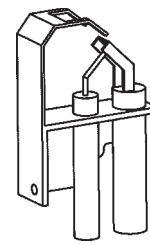

Fig # 9363

IID PILOT

### PILOT REMOVAL

1. Disconnect pilot tubing from gas valve.
2. Remove (4) screws from control box. Open the control box.
3. Remove the pilot wire from the ignition wire.
4. Remove (2) screws that mount the pilot bracket to the air manifold assembly.
5. Pull the pilot bracket downwards and outwards.
6. Reverse above procedure to re-install.

### COMBUSTION FAN REMOVAL

1. Remove burner drawer. See burner drawer removal procedure.
2. Remove (4) screws that mount the combustion blower to the manifold assembly.
3. Reverse above procedure to re-install.

### NORMAL INSPECTION PROCEDURES

First and third month after initial start up and then on an annual basis. If problems are found, refer to Trouble Shooting Guide for additional directions.

1. Remove top of heater and inspect heat exchanger for soot and examine venting system.
2. Remove rear header and inspect for scale deposits.
- \*3. Inspect pilot and main burner flame and firing rate.
- \*4. Inspect and operate all controls and gas valve.
- \*5. Visually inspect system for water leaks.
- \*6. a. Oil pump motor and bearing assembly, if oil cups are provided.
  - b. Disconnect pump from header and check condition of pump impeller. Check condition of bearing by attempting to move impeller from side to side. Replace any parts showing wear.
  - c. Check pump coupler for wear and vibration.
7. Check flow switch paddle (if provided).
8. Clean room air intake openings to assure adequate flow of combustion and ventilation air.

**CAUTION:** Combustion air must not be contaminated by corrosive chemical fumes which can damage the heater and void the warranty.

9. Keep heater area clear and free from combustible materials, gasoline, and other flammable vapors and liquids.

\*Should be checked monthly. (Takes approximately 15 minutes).

## REPAIR SECTION

### TUBE CLEANING PROCEDURE (TYPICAL)

Establish a regular inspection schedule, the frequency depending on the local water condition and severity of service. Do not let the tubes clog up solidly. Clean out deposits over 1/16" in thickness.

The heater may be cleaned from the side opposite the water connections, without breaking pipe connections. It is preferable, however, to remove both headers for better visibility through the tubes and to be sure the residue does not get into the system.

Note that you do not remove the top pan or the heat exchanger generally.

After reaming with the auger, mount the wire brush and clean out the debris remaining in the tubes.

Another method is to remove the heat exchanger, ream tubes and immerse heat exchanger in non-inhibited de-scale solvent.

### HEAT EXCHANGER REMOVAL

1. Shut water, gas and electricity off, close valves and relieve pressure, remove relief valve. Remove side inspection panels.
2. Remove top holding screws.
3. Remove draft diverter, lift and remove top and flue collector on stack type models. Remove inspection panels.
4. Loosen bolts and disconnect flange nuts on inlet-outlet header, loosen union(s) at gas pipe, and slide heater away from piping until studs clear the heater.
5. Remove heat exchanger corner brackets.
6. Remove combustion chamber clips at the four corners of the heat exchanger.
7. Lift heat exchanger straight up using caution not to damage refractory.

## HEAT EXCHANGER RE-ASSEMBLY

1. Heat exchanger water header O-rings should be replaced with new ones.
2. Install inlet-outlet and return water headers and install header retainer nuts and torque nuts evenly.
3. Install the four (4) corner clips between tube sheets and refractory. Replace "V" baffles.
4. Install thermostat sensing bulbs in header wells and replace bulb retaining clips.
5. Install inlet and return pipes in water headers using pipe thread sealant.
6. Install water pressure relief valve, flow switch, and low water cutoff devices if so equipped.
7. Open water supply and return shut-off valves. Fill heater and water piping system with water. Check heater and piping system for leaks at full line pressure. Run system circulating pump for a minimum of 1/2 hour with heater shut-off.
8. Shut down entire system and vent all radiation units and high points in system piping. Check all strainers for debris. Expansion tank water level should be at the 1/4 mark and the balance of the tank filled with air.
9. Install flue collector, jacket top and inspection panels. Install top holding screws. Install draft diverter and vent piping if so equipped.
10. If gas piping was disconnected, reconnect gas piping system and check for leakage using a soap solution.
11. Check for correct water pressure and water level in the system. Make sure that system pump operates immediately on the call for heat. The system is ready for operation.
12. Within two (2) days of start-up, recheck all air vents and expansion tank levels.

### COMBUSTION CHAMBER REMOVAL

To remove combustion chamber you must first have removed the heat exchanger. Unbolt metal combustion chamber retainer from top and remove combustion chamber panels individually.

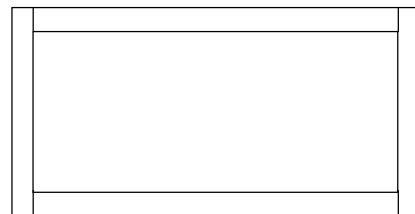

REFRACTORY PANELS TOP VIEW



## 5. TROUBLE SHOOTING GUIDE

### IMPORTANT NOTICE

These instructions are primarily intended for the use of qualified personnel specifically trained and experienced in the installation of this type of heating equipment and related system components. Installation and service personnel may be required by some states to be licensed. Persons not qualified shall not attempt to install this equipment nor attempt repairs according to these instructions.

PROBLEM(S)	CAUSE(S)	SOLUTION(S)
1)When tankstat is turned on, heater does not operate.	1)No power to the heater.  2)Defective tankstat or disconnected wire in thermostat circuit.  3)Defective transformer.	1)Check circuit breakers, disconnect switch. Make sure power is on.  2)Check continuity on thermostat and wiring circuit. Replace thermostat, or repair wiring connections. 3) Check secondary voltage. If no 24V, replace transformer.
2)When tankstat is calling for heat, pump is on, but burners will not turn on.	1) For Standing pilot models pilot burner not lighted. 2) If pilot burner will not stay lighted, thermocouple or gas valve may be defective.  3) Gas knob in "Pilot" position. 4) Vent switch is open.  5) Roll-out switch is open.  6) Manual Reset High limit is open.  7) Fast Response Temperature Sensor probe is defective.  8) Fast Response Temperature sensor board is defective.  9) Defective ignition module or defective gas valve.	1) Light pilot burner. (Follow lighting instructions on rating plate). 2) Check thermocouple MV generation. If less than 25MV (open circuit), replace thermocouple. If between 25-35 MV, replace gas valve. 3) Turn knob to "ON" position. 4) Check for blockage of venting system or disconnected vent piping. After problem is corrected push button to reset vent switch. 5) Check for blockage of flue or sooted heat exchanger. After problem is corrected push button to reset roll-out switch. 6) Check water flow and adjust to obtain 8° to 10°F temperature rise. 7) Red LED on circuit board will be <u>ON</u> to indicate a loose sensor connection or a shorted sensor. Check terminal connectors or replace sensor as required. <b>NOTE:</b> Red LED will also be <u>ON</u> if sensor temperature exceeds 300°F or drops below - 20°F. It will turn <u>OFF</u> when sensor temperature returns to the proper range. Yellow LED will be <u>ON</u> , if temperature exceeds 210°F. When either Red or Yellow LED is <u>ON</u> , heater will be shut down. 8) Check voltage across output and common terminals. If no 24V is present, replace board. 9) On Honeywell module, check voltage across terminals MV and MV/PV. If no 24V is present, replace module. If 24V is present, replace gas valve.



3) Pilot Outage. (Standing pilot models)	<ol style="list-style-type: none"> <li>1) Too low or too high gas pressures.</li> <li>2) Restricted pilot.</li> <li>3) Weak thermocouple.</li> </ol>	<ol style="list-style-type: none"> <li>1) Adjust inlet gas pressure as shown on rating plate.</li> <li>2) Clean pilot orifice.</li> <li>3) Replace thermocouple.</li> </ol>
4) Yellow lazy flame.	<ol style="list-style-type: none"> <li>1) Too low gas pressure.</li> <li>2) Restricted burner intake ports.</li> <li>3) Restricted gas line.</li> </ol>	<ol style="list-style-type: none"> <li>1) Adjust manifold pressure as shown on rating plate.</li> <li>2) Clean burners free of debris or insects.</li> <li>3) Clean gas line or increase gas line piping.</li> </ol>
5) Sooting	<ol style="list-style-type: none"> <li>1) Insufficient combustion air.</li> <li>2) Improper venting.</li> <li>3) Severe yellow burner flames.</li> </ol>	<ol style="list-style-type: none"> <li>1) Refer to installation instructions regarding combustion air requirements.</li> <li>2) Refer to installations instructions.</li> <li>3) See yellow flame section above.</li> </ol>

# TROUBLESHOOTING

## ELECTRICAL (ELECTRONIC IGNITION IID)

### Intermittent Pilot System

### TROUBLESHOOTING HONEYWELL S8600

**WARNING**  
HIGH VOLTAGE  
For qualified Technicians ONLY

---

NOTE: Some heaters may be equipped with an ignition module that shuts off pilot gas if pilot fails to light. To reset, interrupt power to heater.

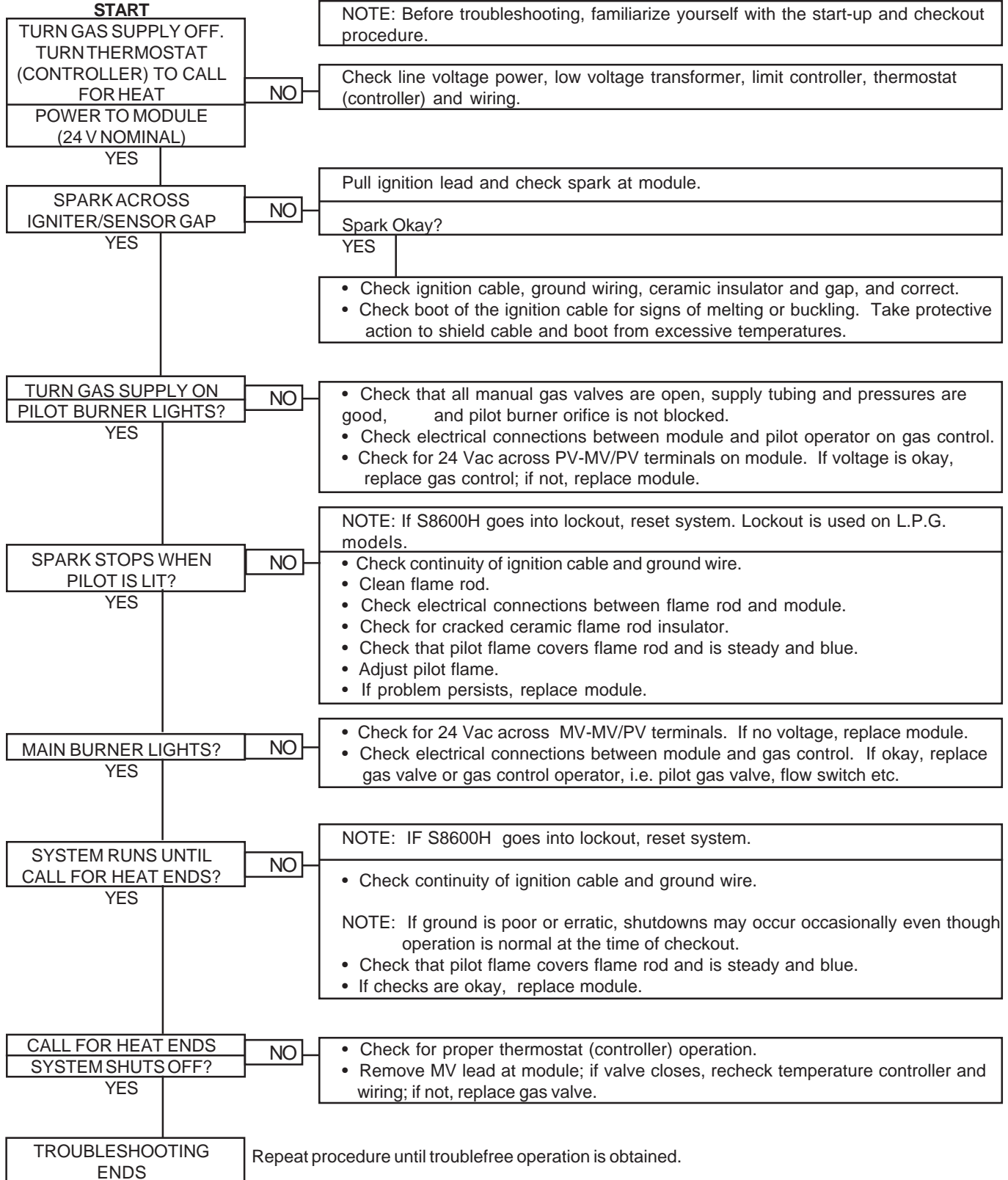

# ELECTRICAL (STANDING PILOT)

## ELECTRICAL TROUBLESHOOTING

For Service Technicians

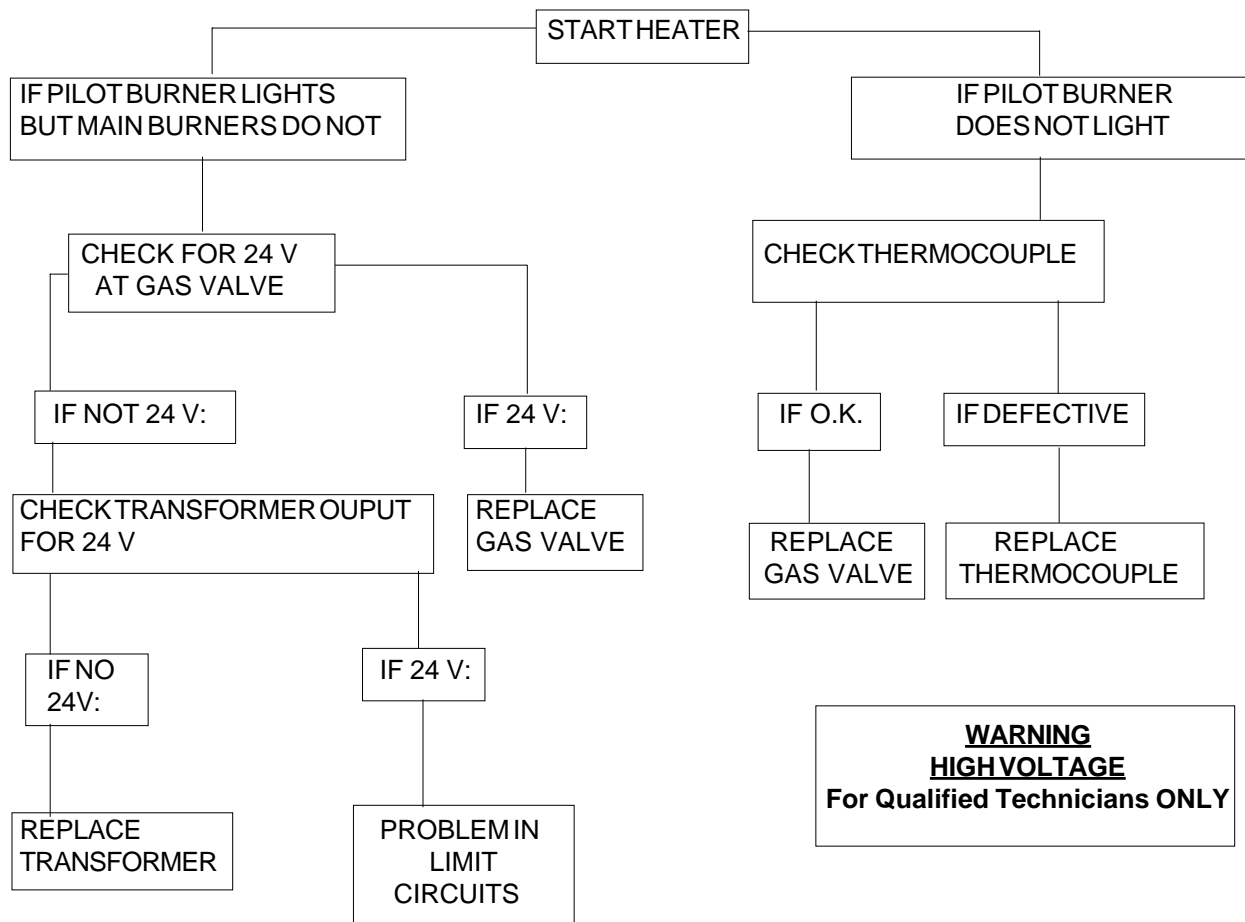

## ADJUSTMENTS/REPLACEMENTS OF COMPONENTS

**CAUTION:** Label all wires prior to disconnection when servicing controls. Wiring errors can cause improper and dangerous operation. Verify proper operation after servicing.

### DANGER - SHOCK HAZARD

Make sure electrical power to the heater is disconnected to avoid potential serious injury or damage to components.

#### GAS VALVE REMOVAL

1. Shut off gas supply to the heater. Remove gas piping to gas valve inlet.
2. Disconnect wires, pilot tubing and bleed line, if required.
3. Turn vertical gas pipe from manifold slightly and unscrew gas valve.
4. Reverse above procedure to re-install.

#### PILOT REMOVAL AND CLEANING

1. Disconnect pilot tubing at pilot and sensor/ignitor wire. Remove screws holding pilot bracket to burner drawer.
2. Remove pilot and bracket, clean pilot of debris, small bugs, etc., with wire or small brush.
3. Replace pilot, pilot tubing, sensor ignition wires and check for leaks.

#### BURNER DRAWER REMOVAL

1. Shut off power and gas supply to the heater. Disconnect union(s) and pilot tubing, then loosen and remove burner hold down screws.
2. Disconnect wires at gas valve and slide burner drawer out.

#### MAIN BURNER AND ORIFICE REMOVAL

1. Remove screws and burner hold down bracket.

*NOTE: If the heat exchanger is sooted badly, the burner hold down bracket and spacer can become distorted from direct flame impingement and this usually necessitates replacement of these parts.*

2. Lift burners from slotted spacer and slide from orifices. Clean with a wire brush.
3. Orifices usually do not need to be replaced. To clean, run either copper wire or wood through orifice. Do not enlarge hole. To remove orifice, use a socket wrench and remove the manifold. DO NOT overtighten when reinstalling.

#### HIGH LIMIT OR TANKSTAT REMOVAL

1. Turn off electrical power.
2. Remove front inspection panel.
3. Remove wires to high limit and loosen screws holding high limit to cabinet.
4. Remove wedge clip holding sensing bulb in control well.
5. Remove high limit and install a new one.
6. Check control operation before leaving job.

#### FLAME ROLL-OUT SWITCH REPLACEMENT

1. Shut off electrical power to the heater.
2. Remove wiring connections to switch.
3. Remove screws (2) holding the switch.
4. Reverse above procedure to re-install.

#### VENT THERMAL SWITCH REPLACEMENT

1. Shut off electrical power to the heater.
2. Remove wiring connections to switch.
3. Remove the screws (2).
4. Reverse above procedure to re-install.

#### IGNITION MODULE REPLACEMENT

1. Shut off electrical power to the heater.
2. Remove control cover screws and open control compartment.
3. Disconnect wiring connections to module.
4. Remove screws (2) holding module.
5. Reverse above procedure to re-install.

#### TRANSFORMER REPLACEMENT

1. Shut off electrical power to the heater.
2. Remove control cover screws and open control compartment.
3. Disconnect wiring connections from transformer leads.
4. Remove screws (2) holding transformer.
5. Reverse above procedure to re-install.

#### CIRCULATOR REPLACEMENT

1. Shut off electrical power to the heater.
2. Shut off water supply and open drain valve to remove water in the piping at the pump level.

**CAUTION:** To avoid damage to electrical components keep water from getting into the control compartments and gas valve.

3. Disconnect wiring and conduit connections to the pump.
4. Remove the nuts and bolts at the inlet and outlet flanges. Remove old gaskets.
5. Remove the pump.
6. Reverse the above procedure to re-install. Use new gaskets and make sure they are seated properly when tightening the nuts and bolts.

## CONTROL WELL REPLACEMENT

Remove top, sensing bulb and clip. Collapse well tube at the open end with a chisel, push through into header and remove the well through header. Insert a new well and roll into place. If a roller is not available, solder the well in place with silver solder.

## TUBE REPLACEMENT PROCEDURE

1. Remove heat exchanger from heater following instructions outlined under HEAT EXCHANGER REMOVAL.
2. Remove inlet/outlet and return headers. Remove "V" Baffle from damaged tube.
3. Remove damaged tube by cutting with a hack saw or shearing with a chisel adjacent to each tube sheet.
4. Collapse stub ends in tube sheets using a chisel or screwdriver. **DO NOT** cut into tube sheet or mar surface in tube hole in any way.
5. Insert replacement tube by inserting the end with the most fins removed in the opening of one tube sheet. Slide tube until the opposite end clears the other tube sheet and fits the tube into the hole.
6. Insert the tube roller into tube opening up to stop, making certain that 1/8" of tube projects beyond the tube sheet.
7. Attach drill to tube roller, holding it straight and level.

*NOTE: Use a 3/8" heavy duty, reversible, electric drill or larger. Proceed to expand tube until tool starts to grab. Approximately 1/2 to 1" of the tool shank will be visible.*

8. Reverse drill motor and withdraw tube roller, if necessary wrench out by hand.
9. **DO NOT** apply excessive torque during rolling operation and avoid thinning any wall of the tube beyond 0.015".
10. Use same procedure on opposite end.
11. Apply line pressure test. Re-roll if necessary.
12. Reinstall as outlined under HEAT EXCHANGER REASSEMBLY.

## PROCEDURE FOR CLEANING FLUE GAS PASSAGE-WAYS

Soot will clog areas behind fins and cause eventual tube failure. Any sign of soot at base of burners or around outer jacket indicates a need for cleaning.

1. Lift off draft hood and flue collector by removing bolts and screws.
2. Remove "V" baffles from heat exchanger.
3. Remove burner tray, see Burner Drawer Removal.
4. Take garden hose and wash heat exchanger, making sure soot is removed from between fins. (Avoid excessive water against refractory).
5. Reassemble; when heater is fired, some steam will form from wet refractory. This is normal.

**NOTE:** *In extreme cases it may be necessary to remove the heat exchanger completely for cleaning. The simplest method is steam cleaning at a local car wash.*

**CAUTION:** *Soot is combustible. Exercise extreme care. Do not wire brush.*

## REPLACEMENT PARTS LIST

**NOTE:** *To supply the correct part it is important that you state the model number, serial number and type of gas when applicable.*

Any part returned for replacement under standard company warranties must be properly tagged with RAYPAK return parts tag, completely filled in with the heater serial number, model number etc., and shipped to the Company freight prepaid.

If determined defective by the Company and within warranty, the part will be returned in kind or equal substitution, freight collect. Credit will not be issued.

**RAYPAK, INC.**  
**2151 Eastman Avenue**  
**Oxnard, CA 93030**

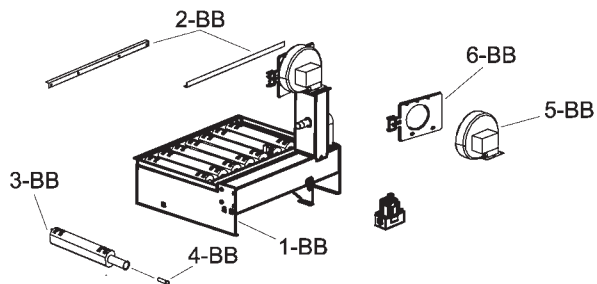
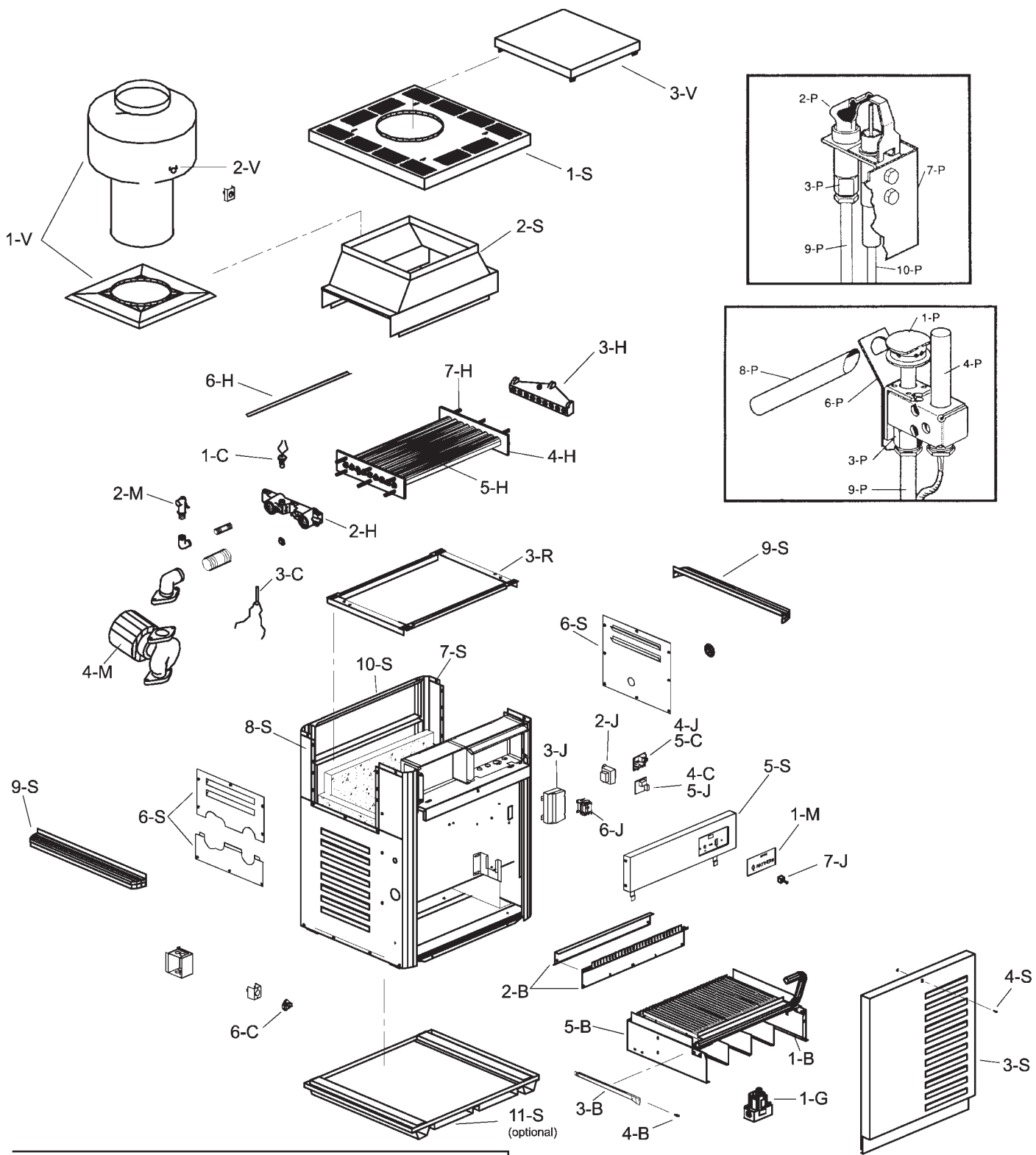

FOR UNITS WITH A LOW NO<sub>x</sub> TRAY

CALL OUT	DESCRIPTION	260/261	330/331	400/401
<b>B</b>	<b>BURNER TRAY (Atmospheric)</b>	260	330	400
1-B	Burner Tray w/Burners (Sea Level)* Burner Tray w/o Burner (Sea Level)*	005214F 005218F	005215F 005219F	005216F 005220F
2-B	Burner Spacer/Hold Down Kit	005238F	005239F	005240F
3-B	Burner	301210/19	301210/24	301210/29
4-B	Burner Orifice Nat. #51 (Sea Level)* Burner Orifice Pro. #57 (Sea Level)*	350080F/19 350083F/19	350080F/24 350083F/24	350080F/29 350083F/29
5-B	Burner Tray w/o Manifold w/o burners	005266F	005267F	005268F
<b>BB</b>	<b>BURNER TRAY (Fan Assisted Low Nox)</b>	261	331	401
1-BB	Burner Tray w/Burners (Sea Level)* Burner Tray w/o Burner (Sea Level)*	007995F 007999F	007996F 008000F	007997F 008001F
2-BB	Burner Hold Down Kit	008003F	008004F	008005F
3-BB	Burner	309255/5	309255/6	309255/7
4-BB	Burner Orifice Nat. #30 (Sea Level)*	351510/5	351510/6	351510/7
5-BB	Blower	008080F	008080F	008080F
6-BB	Air Shutter	008134F	008134F	008134F
<b>C</b>	<b>CONTROLS</b>			
1-C	Manual reset Limit	008093F	008093F	008093F
2-C	Electronic Fast Response Sensor w/Probe(Not Shown)	005555F	005555F	005555F
3-C	Probe Fast Response	006532F	006532F	006532F
4-C	Electronic Fast Response Sensor	005197F	005197F	005197F
5-C	Economaster II Control	004675F	004675F	004675F
6-C	Flame Roll-Out Sensor	006035F	006035F	006035F
7-C	Tankstat (Not Shown)	007148F	007148F	007148F
8-C	Flow Switch	007142F	007142F	007142F
<b>G</b>	<b>GAS VALVE</b>			
1-G	Valve - Comb. Step 3/4" (IID Units) Nat Valve - Comb. Step 3/4" (IID Units) Pro Valve - Combination Step 3/4" STG Nat Valve - Combination Step 3/4" STG Pro Valve - Comb. Step 3/4" (Low Nox) Nat	003900F 006058F 004868F 006375F 010812F	003900F 006058F N/A N/A 010812F	003900F 006058F N/A N/A 010812F
<b>H</b>	<b>HEAT EXCHANGER</b>			
1-H	Heat Exchanger Assy Cast Iron	008072F	008073F	008074F
2-H	Inlet/Outlet Header Cast Iron	006070F	006070F	006070F
3-H	Return Header Cast Iron	002042F	002042F	002042F
4-H	Tube Bundle	008023F	008024F	008025F
5-H	Heat Exchange Tube	008031F	008032F	008033F
6-H	Baffle Kit	008039F	008040F	008041F
7-H	Stud Bolt Kit	007870F	007870F	007870F
8-H	Header Gasket	800203B	800203B	800203B
9-H	Sensor Well	007211F	007211F	007211F
10-H	Well Retaining Clip	300203	300203	300203
<b>J</b>	<b>CONTROL BOX</b>			
1-J	Control Box STD/TTD Control Box Lock/TTD Control Box Lock/TTD Low Nox	008075F 008076F 008094F	N/A 008077F 008095F	N/A 008078F 008096F
2-J	Transformer 50VA	006533F	006533F	006533F
3-J	Ignition Control Lock. IID	004818B	004818B	004818B
4-J	Economaster II Control	004675F	004675F	004675F
5-J	Electronic Fast Response Sensor	005197F	005197F	005197F
6-J	Relay Low Nox Blower	007377F	007377F	007377F
7-J	Toggle Switch	008079F	008079F	008079F

\*FOR ALTITUDES ABOVE 2,000 FEET LEVEL, CONSULT THE FACTORY



CALL OUT	DESCRIPTION	260/261	330/331	400/401
<b>M</b>	<b>MISCELLANEOUS COMPONENTS</b>			
1-M	Switch Plate IID	901613	901613	901613
2-M	PRV 125 PSI	007224F	007224F	007224F
3-M	Delimiting Kit	052871F	052871F	052871F
4-M	Pump Brass	005574	005574	005574
5-M	Vertical Thermometer (Not shown)	600133	600133	600133
<b>P</b>	<b>PILOT</b>			
1-P	Pilot Nat. Standing	002001F	N/A	N/A
	Pilot Pro. Standing	002002F	N/A	N/A
2-P	Pilot Nat. IID Atmospheric	002003F	002003F	002003F
	Pilot Pro. IID Atmospheric	002003F	002003F	002003F
	Pilot Nat. IID Low Nox	008155F	008155F	008155F
3-P	Pilot Orifice Nat. Standing	600002	N/A	N/A
	Pilot Orifice Pro. Standing	600422	N/A	N/A
	Pilot Orifice Nat. IID .020	003903F	003903F	003903F
	Pilot Orifice Pro. IID .012	004308F	004308F	004308F
4-P	Thermocouple (Standing Pilot)	600003	N/A	N/A
5-P	Ignition Control Lock. IID	004818B	004818B	004818B
6-P	Pilot Mounting Bracket Std. Atmospheric	306693	N/A	N/A
7-P	Pilot Mounting Bracket IID Atmospheric	306692	306692	306692
	Pilot Mounting Bracket IID Low Nox	008082F	008082F	008082F
8-P	Lighter Tube (Standing Pilot)	062996	N/A	N/A
9-P	Pilot Tube (Specify Length)	400607	400607	400607
10-P	Hi Tension Wire w/ Pilot Electrode	007864F	007864F	007864F
<b>R</b>	<b>REFRACTORY</b>			
1-R	Refractory Common (Left & Right)	005282F	005282F	005282F
2-R	Refractory Uncommon (Front & Rear)	005284F	005285F	005286F
3-R	Refractory Retainer Kit	005288F	005289F	005290F
<b>S</b>	<b>SHEETMETAL</b>			
1-S	Jacket Top (Louvered)	005304F	005305F	005306F
2-S	Flue Collector	005308F	005309F	005310F
3-S	Door Assy.	005316F	005317F	005318F
4-S	Screw & Retainer	006744F	006744F	006744F
5-S	Control Panel	008065F	008066F	008067F
6-S	Access Panel	008071F	008071F	008071F
7-S	Side Panel Right	008068F	008068F	008068F
8-S	Side Panel Left	008069F	008069F	008069F
9-S	Side Panel Cap	008070F	008070F	008070F
10-S	Rear Panel Kit (2 Pcs.)	005279F	005280F	005281F
11-S	Sub-Base for Combustible Flooring	005183	005184	005185
<b>V</b>	<b>VENTING</b>			
1-V	Draft Hood Kit	008085	008148	008149
2-V	Flue Gas Spillage Sensor	006021F	N/A	N/A
3-V	"Pagoda" Top	007991	007992	007993

**LIMITED PARTS WARRANTY ECONOPAK WATER HEATERS  
MODELS WH - 260 TO 401**

**SCOPE:**

Raypak, Inc. ("Raypak") warrants to the original owner that all parts of this water heater which are actually manufactured by Raypak will be free from failure under normal use and service for the specified warranty periods and subject to the conditions set forth in this Warranty. Labor charges and other costs for parts removal or reinstallation, shipping and transportation are not covered by this Warranty but are the owner's responsibility.

**HEAT EXCHANGER WARRANTY:**

- Five (5) Years from date of water heater installation. This includes only the copper, bronze and cast iron waterways.
- Twenty (20) Years from date of water heater installation against "Thermal Shock" (excluded, however, if caused by operation at large changes exceeding 150°F between the water temperature at intake and water heating temperature, or operating at water heater temperatures exceeding 190°F).

**ANY OTHER PART MANUFACTURED BY RAYPAK:**

One (2) year warranty from date of installation, or eighteen (18) months from date of factory shipment based on Raypak's records, whichever comes first.

SATISFACTORY PROOF OF INSTALLATION DATE, SUCH AS INSTALLER INVOICE, IS REQUIRED. THIS WARRANTY WILL BE VOID IF THE WATER HEATER RATING PLATE IS ALTERED OR REMOVED.

**ADDITIONAL WARRANTY EXCLUSIONS:**

This warranty does not cover failures or malfunctions resulting from:

1. Failure to properly install, operate or maintain the water heater in accordance with our printed instructions provided;
2. Abuse, alteration, accident, fire, flood and the like;
3. Sediment or lime buildup, freezing, or other conditions causing inadequate water circulation;
4. High velocity flow exceeding water heater design rates;
5. Failure of connected systems devices, such as pump or controller;
6. Use of non-factory authorized accessories or other components in conjunction with the water heater system;
7. Failing to eliminate air from, or replenish water in, the connected water system;
8. Chemical contamination of combustion air or use of chemical additives to water.

**PARTS REPLACEMENT:**

Under this Warranty, Raypak will furnish a replacement for any failed part. The failed part must first be returned to Raypak if requested, with transportation charges prepaid, and all applicable warranty conditions found satisfied. The replacement part will be warranted for only the unexpired portion of the original warranty. Raypak makes no warranty whatsoever on parts not manufactured by it, but Raypak will apply any such warranty as may be provided to it by the parts manufacturer.

**TO MAKE WARRANTY CLAIM:**

Promptly notify the original installer, supplying the model and serial numbers of the unit, date of installation and description of the problem. The installer must then notify his Raypak distributor for instructions regarding the claim. If either is not available, contact Service Manager, Raypak, Inc., 2151 Eastman Avenue, Oxnard, CA 93030 or call (805) 278-5300. In all cases proper authorization must first be received from Raypak before replacement of any part.

**EXCLUSIVE WARRANTY - LIMITATION OF LIABILITY:**

This is the only warranty given by Raypak. No one is authorized to make any other warranties on Raypak's behalf. THIS WARRANTY IS IN LIEU OF ALL OTHER WARRANTIES, EXPRESS OR IMPLIED, INCLUDING BUT NOT LIMITED TO IMPLIED WARRANTIES OF MERCHANTABILITY AND FITNESS FOR A PARTICULAR PURPOSE. RAYPAK'S SOLE LIABILITY AND THE SOLE REMEDY AGAINST RAYPAK WITH RESPECT TO DEFECTIVE PARTS SHALL BE AS PROVIDED IN THIS WARRANTY. IT IS AGREED THAT RAYPAK SHALL HAVE NO LIABILITY, WHETHER UNDER THIS WARRANTY, OR IN CONTRACT, TORT, NEGLIGENCE OR OTHERWISE, FOR ANY SPECIAL, CONSEQUENTIAL, OR INCIDENTAL DAMAGE, INCLUDING DAMAGE FROM WATER LEAKAGE. Some states do not allow limitations on how long an implied warranty lasts, or for the exclusion of incidental or consequential damages. So the above limitation or exclusion may not apply to you.

This Limited Warranty gives you specific legal rights. You may also have other rights which may vary from state to state. We suggest that you complete the information below and retain this certificate in the event warranty service is needed. Reasonable proof of the effective date of the warranty (date of installation) must be presented, otherwise, the effective date will be based on the rate of manufacture plus thirty (30) days.

Name of Owner	Name of Dealer
Address	Address
Model No.	Serial No.
Date of Installation: _____	Date of Initial Operation: _____

**CORPORATE HEADQUARTERS:**

RAYPAK, INC., 2151 Eastman Avenue, Oxnard, CA 93030 (805) 278-5400 FAX (805) 278-5489



[www.raypak.com](http://www.raypak.com)

**Raypak, Inc.**, 2151 Eastman Avenue, Oxnard, CA 93030 (805) 278-5300 FAX (800) 872-9725  
**Raypak Canada LTD**, 2805 Slough Street, Mississauga, Ontario, Canada L4T 1G2 (905) 677-7999 FAX (905) 677-8036  
Litho in U.S.A.